



THE NEW CLE CABRIOLET

Mercedes-Benz





## DESIRE UNFOLDS.

The new CLE Cabriolet is perfect for all those who want outstanding design, dynamic driving pleasure and the chance to experience within a matter of seconds the feeling of freedom an open-top car gives them. Not to mention an extensive array of exclusive comfort features to choose from – in a combination that only Mercedes-Benz can offer.

## IMPOSING FRONT-END DESIGN.

The new CLE Cabriolet combines the sporty design elements of the CLE Coupé – a powerful front end, including a deep-faced bonnet and expressive powerdomes – with the stylish fabric acoustic soft top. Equally striking are the new-look LED headlamps with DIGITAL LIGHT.





## EXPRESSIVE AND PERFECTLY FORMED.

Bright spots from every perspective – the seamlessly flowing rear design with two-part rear lights and a connecting design element create a striking light setting for the CLE Cabriolet, lending it a self-assured, sporty look.



## FULLY AUTOMATIC FABRIC ACOUSTIC SOFT TOP.

Available in a choice of three colours, the fully automatic fabric acoustic soft top<sup>1</sup> ensures a high level of comfort as well as providing insulation against external noise and protection from hot or cold temperatures – leaving you to enjoy the ride in good hands in every respect, whatever the season.

<sup>1</sup>Optionally selectable equipment depending on configuration.

A high-angle, close-up photograph of the interior of a Mercedes-Benz CLE Cabriolet. The view is from the driver's side, looking towards the passenger side. The dashboard is a dark, textured material with three circular air vents. The center console features a large, vertical touchscreen displaying a grid of colorful app icons (Apps, Routines, Settings, Comfort, Phone, Radio, Media, Info) and climate controls. The steering wheel is black with the Mercedes-Benz logo in the center. The seats are upholstered in a light-colored, perforated leather. The overall aesthetic is modern and luxurious.

## THE INTERIOR OF THE NEW CLE CABRIOLET.

A mosaic of luxurious highlights in the interior lends the new CLE Cabriolet a high-quality overall look of the very highest standard. Impressive details such as the instrument panel and beltlines in nappa-look ARTICO man-made leather, the comfortable multicontour seats<sup>1</sup> and the first-class worlds of sound courtesy of the Burmester® 3D surround sound system<sup>1</sup> provide an all-round, unique driving feeling – with the top up or down.

<sup>1</sup>Optionally selectable equipment depending on configuration.



## EXCLUSIVE OPEN-TOP DRIVING COMFORT.

The front seats in the new CLE Cabriolet feature AIRSCARF headroom heating<sup>1</sup> for an ideal temperature sensation at neck level. Speakers integrated into the seats deliver an engaging surround sound experience for the driver and front passenger.<sup>1</sup>

<sup>1</sup>Optionally selectable equipment depending on configuration.



## Burmester® 3D surround sound system.

Immerse yourself in the sound experience – the Burmester® 3D surround sound system<sup>1</sup> provides high-quality sound for the front and rear occupants, with elegant, metal speaker covers displaying Burmester® lettering adding extra notes of refinement. The additional speakers integrated in the front seats optimise the ambient sound.

<sup>1</sup>Optionally selectable equipment depending on configuration.

## Ambient lighting plus.

Design the interior according to your personal preferences. Ambient lighting plus<sup>1</sup> with indirectly illuminating light lines extends through the entire interior to between the rear seats and gives you unlimited possibilities with 64 colours.

## 48.3 cm (19-inch) light-alloy wheels as standard, optionally up to 50.8 cm (20-inch).

Standards remain high, even at the lowest point of the vehicle – in keeping with the character of the CLE Cabriolet, there is a choice of aerodynamically optimised light-alloy wheels from 48.3 cm (19-inch) to 50.8 cm (20-inch)<sup>1</sup>, all of which create a powerful appearance in tandem with the flared wheel arches.

<sup>1</sup>Optionally selectable equipment depending on configuration.

## Cabriolet Comfort Package.

Make the cabriolet season last all year round – with the AIRSCARF headroom heating, AIRCAP draught-stop system and fully electric boot partition on board, the CLE Cabriolet ensures optimum comfort on every trip, whatever the season.





## New-generation MBUX.

The future of intuitive operation – the new MBUX infotainment generation<sup>1</sup> offers numerous functions, interaction options and the automation of routines. Intuitively controllable by voice or touch. Seamlessly integrated into your digital life and individually customisable with personalised display styles.

<sup>1</sup>Optionally selectable equipment depending on configuration.

<sup>2</sup>Use of these services requires a personal Mercedes me ID and agreement to the Terms of Use for the Mercedes me connect services. Furthermore, the vehicle must be paired with the corresponding user account. After the original term has expired, the services can be extended for a fee, provided that they are still offered for the vehicle in question at this point in time. Initial activation of the services is possible within one year of initial registration of the vehicle or operation by the customer, whichever comes first. Use of the MBUX Entertainment Plus Package also requires the customer's own data volume. In order to use certain apps via the Mercedes me connect service, a separate customer-specific contract with the app provider may be necessary.



## Driving Assistance Package Plus<sup>1</sup> (optional).

Arrive feeling more relaxed – Thanks to state-of-the-art, intelligently networked sensor systems you enjoy the various advantages of partially automated driving. Numerous assistance systems support you as the situation requires, warning you if there is a risk of collision and intervening if necessary – for the benefit of all road users.

<sup>1</sup>This equipment is also available as an on-demand feature for subsequent activation in the vehicle. This requires you to register on the Mercedes me Portal, agree to the Terms of Use for the Mercedes me connect services and link the vehicle, at least temporarily, to the user account. In addition, activation requires a data connection to the vehicle and appropriate equipment fitted to the vehicle. The selected on-demand feature is then permanently activated for use in the vehicle, even if you subsequently cancel the Mercedes me connect services and unlink the vehicle from the user account. You can find out more about the technical requirements through Mercedes me or your authorised Mercedes-Benz dealer.

## Engines that exactly match your ambitions.

Getting you to your destination while giving you a scintillating driving experience every time is what drives us, you can be sure of progressive driving pleasure on every trip in the new CLE Cabriolet.

## AMG Line.

The AMG Line gives the exterior a sporty and exclusive aura from every angle. The AMG Bodystyling and AMG light-alloy wheels in particular give your CLE Cabriolet an individual look. The sports suspension with sports Direct-Steer system ensures an even sportier driving experience. With the AMG Line interior, you make an emphatic statement and show immediately what matters to you – an ambience that is dynamic and exclusive in every detail.

## Night Package<sup>1</sup> (optional).

With this optional package, much of the detailing on the sporty exterior of the new CLE Cabriolet becomes even more expressive in high-gloss black – from the louvre in the radiator grille with Mercedes-Benz pattern and the striking AMG front apron to the large AMG light-alloy wheels and the exterior mirror housings.



<sup>1</sup>Optionally selectable equipment depending on configuration.



## Technical data.

<b>Petrol engine</b>	
<b>CLE 200 Cabriolet AMG Line</b>	
No. of cylinders/arrangement	4/In-line
Displacement (cc)	1,999
Rated output (kW[hp]/rpm)	150[204] / 5,800
Rated torque (Nm/rpm)	320 / 1,600 - 4,000
Acceleration 0 - 100 km/h (s)	7.9
Top speed (km/h)	236
Fuel consumption, combined (L/100km)	7.1
VES band	C1

**The best for the engine:**  
Mercedes-Benz genuine engine oils.

The availability of the communication module (LTE) is temporarily limited for certain vehicles due to supply bottlenecks. Please note that especially Mercedes me connect services including the emergency call system (eCall) are not available in the affected vehicles upon delivery. For further enquiry, please contact your Mercedes-Benz Sales Representative or Cycle & Carriage Customer Assistance Centre at 6471 9111. 1 Rated output and torque figures in accordance with Directive 80/1269/EEC in the currently applicable version. 2 Fuel consumption figures are derived from combined tests & tested by local regulations in accordance with UN ECE R101. Under real-life driving conditions deviations may occur in comparison to the certified standard values. The actual values are influenced by a number of individual factors, such as personal driving style, environmental and route conditions. Further technical data may be found on [www.mercedes-benz.com.sg](http://www.mercedes-benz.com.sg).

## Dimensions.

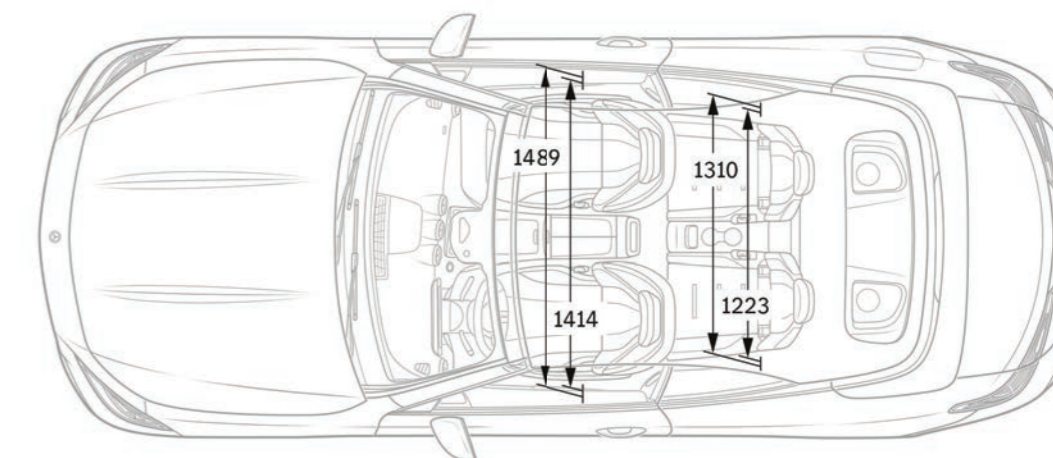
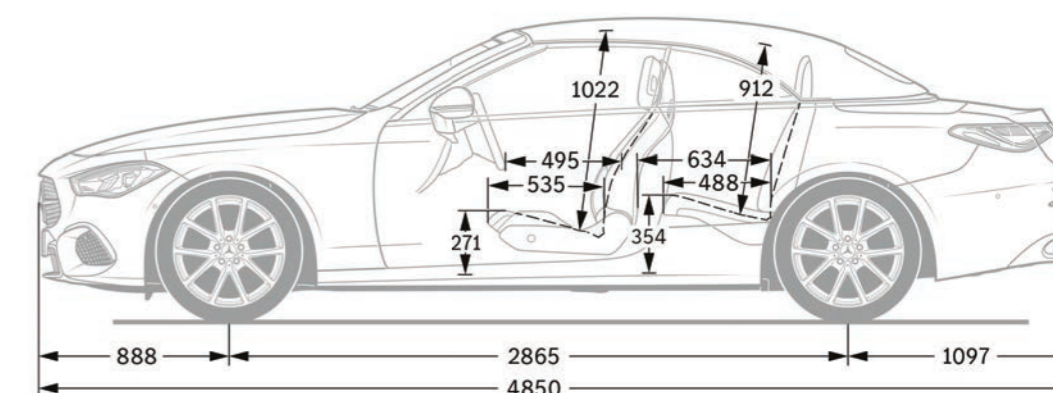
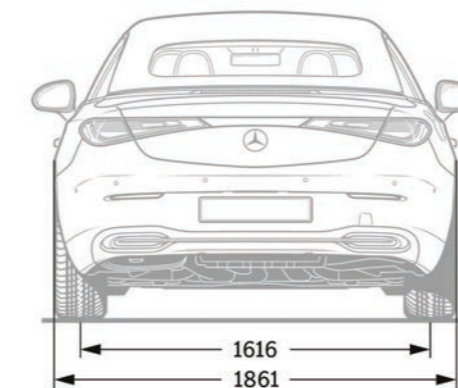
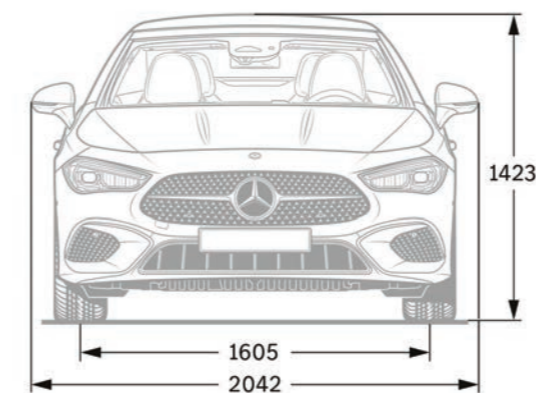

All figures in millimetres. The dimensions shown are mean values. They are valid for vehicles with standard equipment and in unladen condition.

**Please note:** changes may have been made to the product since the editorial deadline (August 2024). The manufacturer reserves the right to make changes to the design, form, colour and the product specification during the delivery period, provided these changes, while taking into account the interests of the vendor, can be deemed reasonable with respect to the purchaser. Where the vendor or the manufacturer uses symbols or numbers to describe an order or the subject of an order, no rights may be derived solely from these. The illustrations may show accessories and items of optional equipment which are not part of standard specification.

This publication is distributed internationally. However, information regarding statutory regulations, legal requirements and taxation and the consequences thereof applies to the Federal Republic of Germany only and is correct at the time of the editorial deadline. For the definitive latest information, please contact your nearest authorised Mercedes-Benz AG sales partner.

**[www.mercedes-benz.com.sg](http://www.mercedes-benz.com.sg)**

Mercedes-Benz Singapore Pte. Ltd.



**CYCLE & CARRIAGE**

**Mercedes-Benz Singapore Customer Care Center:** 1800 329 7540 · [cs.sgp@cac.mercedes-benz.com](mailto:cs.sgp@cac.mercedes-benz.com)

**Cycle & Carriage (Authorised Dealer) – Showroom Enquiries:** 6298 1818.

Mercedes-Benz Center, 301 Alexandra Road, Singapore 159968. Mon – Sat: 8.30 am – 7 pm, Sun & PH: 10 am – 6 pm.