



The new all-electric EQA

Mercedes-Benz



Switch On to Stand Out.

Urban electric luxury has arrived, in style. The sleek and striking new all-electric EQA stands out beautifully with a muscular, self-assured design that will bring compliments rolling in. From the iconic front panel through to the panoramic sunroof¹ and elegantly curved rear light bar, it's certain to turn heads. And, with a range of up to 560 km according to WLTP on one charge², the switch to all-electric is now effortlessly attractive.



¹Optional equipment depending on the individual configuration.

²The stated figures are the determined "WLTP CO₂ figures" in accordance with Article 2, No. 3, of Implementing Regulation (EU) 2017/1153. Fuel consumption figures have been calculated on this basis. The electrical consumption and range have been determined on the basis of Regulation (EU) 2017/1151.



Elegant. Eye-catching.

The new all-electric EQA knows how to make an entrance. The newly designed black panel grille with Mercedes-Benz pattern merges with the LED light band to create a distinctive and confident presence, enhanced by the discreetly simulated power domes. All-electric has never looked so dazzlingly attractive.



Tunes, tailored.

The intuitive personalised MBUX Entertainment¹ system quickly learns your personal taste. It will offer up music playlists, radio stations, ambient lighting and front passenger comfort settings that reflect your preferences, match your mood and transform every journey into a stand-out experience.

¹To use the digital service "MBUX Entertainment", a separate customer-specific contract with a third-party streaming provider and the customer's own data volume are required. In addition, the respective vehicle must be linked to the user account. Country restrictions apply due to the availability of streaming providers services. For the usage of the Digital Extras services and on-demand features, a Mercedes me ID is needed and the Terms of Use for Digital Extras services accepted.



Charging made easy.

Onboard, Navigation with Electric Intelligence¹ makes the switch to all-electric simple and seamless. You'll know whether you'll need to recharge before reaching your destination and the location of handy charging stations.

Immerse yourself (Optional).

Transform your journeys with outstanding sound you can feel through your body. The optional Burmester® Surround-Soundsystem with Dolby Atmos^{®2} delivers stunning sound from 12 speakers.

Advanced displays.

Head-up-Display¹ projects key information onto the windscreen so it can be seen at a glance. Two sporty 10.25-inch screens¹ give you the full picture, including MBUX Augmented Reality for navigation^{1,2} which combines maps with real time images.

Sit back and relax.

Whether it's listening to Spotify favourites or whiling away time with minigames³, MBUX Entertainment^{1,4} makes long journeys short. When you're ready to change the playlist, simply say 'Hey Mercedes' and tell the voice assistant.

¹To use the Digital Extras services, you must create a Mercedes me ID and agree to the Terms of Use for the Digital Extras services. The services presented and their availability and functionalities depend in particular on time, the vehicle model, year of manufacture, selected optional equipment and country.

²Optional equipment depending on the individual configuration.

¹Optional equipment depending on the individual configuration. ²To use the Digital Extras services, you must create a Mercedes me ID and agree to the Terms of Use for the Digital Extras services. The services presented and their availability and functionalities depend in particular on time, the vehicle model, year of manufacture, selected optional equipment and country. ³For safety reasons, it is not possible to play while driving. ⁴To use the digital service "MBUX Entertainment", a separate customer-specific contract with a third-party streaming provider and the customer's own data volume are required. In addition, the respective vehicle must be linked to the user account. Country restrictions apply due to the availability of streaming providers services. For the usage of the Digital Extras services and on-demand features, a Mercedes me ID is needed and the Terms of Use for Digital Extras services accepted.



All at your fingertips.

With Touch Control, both the driver display and central touchscreen can be controlled from the newly designed three-spoke steering wheel. Allowing you to adjust the multimedia system volume, use the cruise control and more. All without taking your eyes off the road or hands off the wheel.

¹Optional equipment depending on the individual configuration.

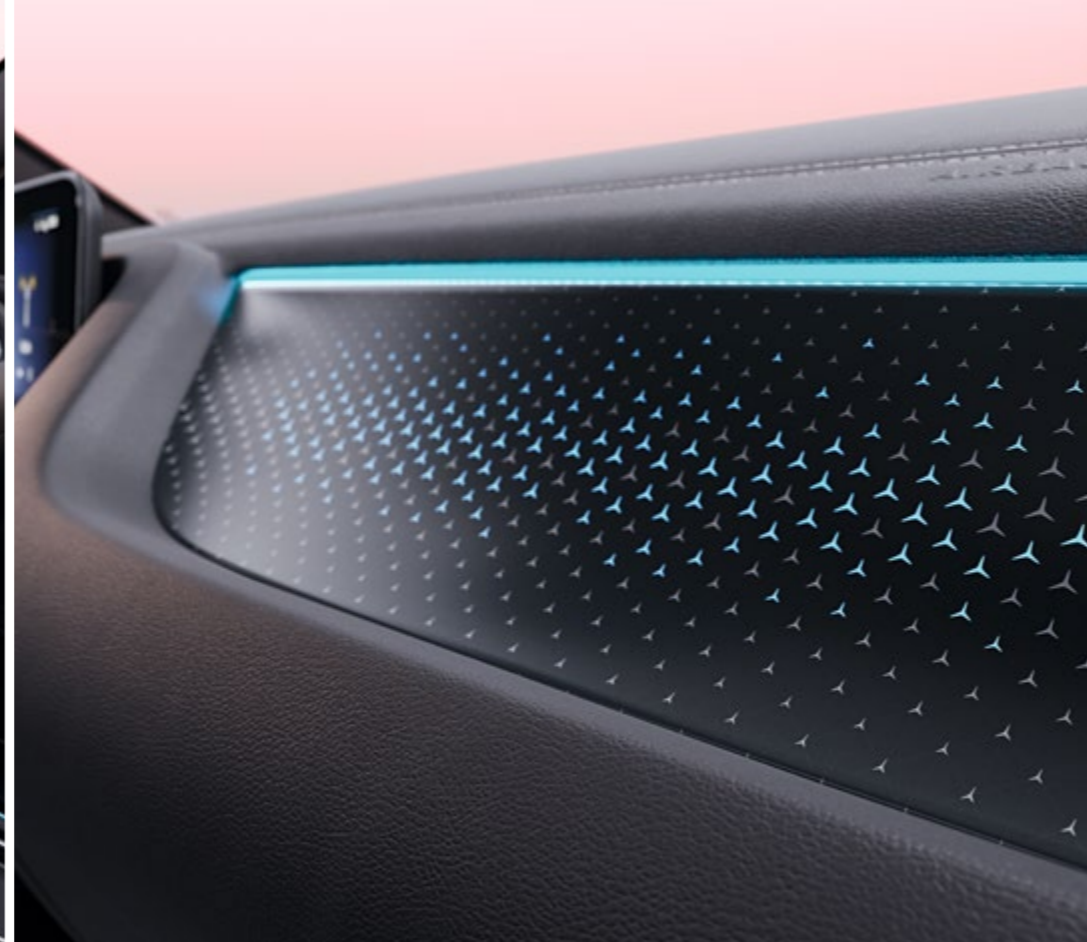

Light. Fantastic.

The illuminated star pattern¹ makes an immediate stand-out statement. Inside, you can bathe the cabin in ambient lighting and tailor the settings to suit your personal taste. You have 64 colours which can alternate dynamically or illuminate various areas in different colours.



Comfort. Controlled.

The new all-electric EQA gives you the space to sit back and relax with plenty of legroom. Seats are created using progressive materials in a style that underlines the car's sporty design. You can adjust the rear seats to create extra space and even opt for front seats¹ that remember your preferred settings.

¹Optional equipment depending on the individual configuration.

Progressive.

The Progressive equipment line substantially enhances your car. Added value that you can see and feel: for example, with comfort suspension seats in ARTICO man-made leather and Bertrix fabric including the Seat Comfort Package or the leather steering wheel. Aerodynamic 18-inch light-alloy wheels refine the exterior.

Images may show additional items of special equipment.



Images may show additional items of special equipment.



Electric Art.

Distinctive backlit decorations and colour accents in rose gold make you feel truly part of the EV generation. The advanced interior features ARTICO man-made leather, Cupertino two-tone fabric in rose gold and titanium grey pearl, a star pattern trim and multifunction sports steering wheel in nappa leather.

Technical data.

	EQA 250+ Progressive	EQA 250+ Electric Art
Rated output (kW [hp])	140 [190]	
Rated torque (Nm)	385	
Acceleration 0 - 100 km/h (sec)	8.6	
Top speed (km/h)	160	
Range in km (WLTP)	Up to 569 km	
Power consumption (kWh/100km)	18.4	
VES band	A1	

Dimensions.

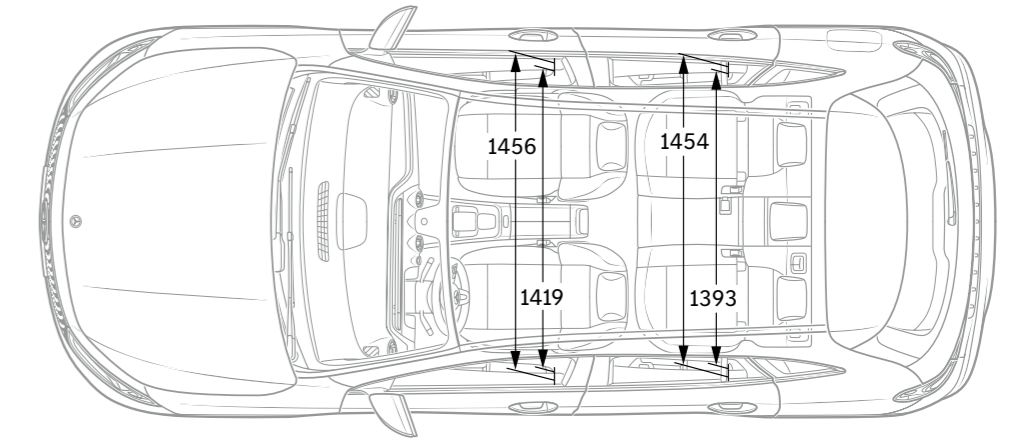
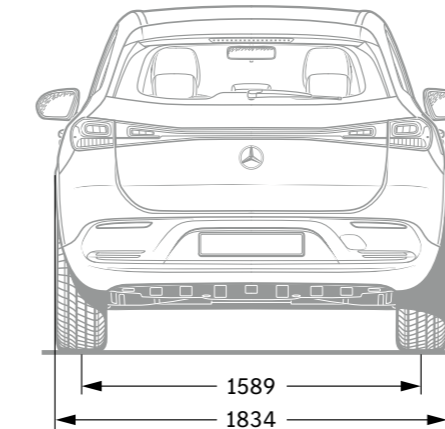
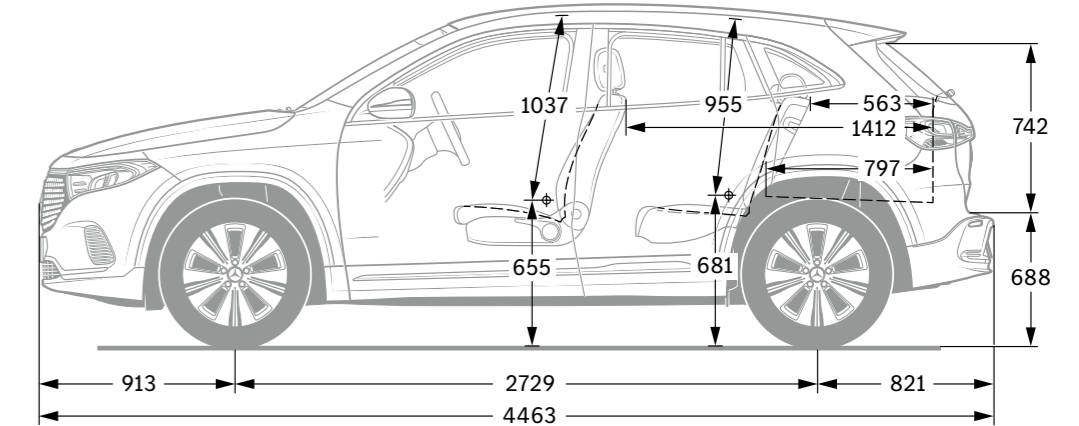
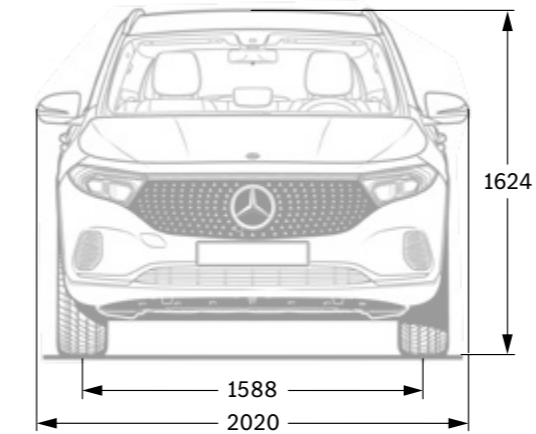

Rated output and torque figures in accordance with Directive 80/1269/EEC in the currently applicable version. Energy consumption figures are derived from combined tests & tested by local regulations in accordance with UN ECE R101. Under real-life driving conditions deviations may occur in comparison to the certified standard values. The actual values are influenced by a number of individual factors, such as personal driving style, environmental and route conditions. Further technical data may be found on www.mercedes-benz.com.sg

All figures in millimetres. The dimensions shown are mean values. They are valid for vehicles with standard equipment and in unladen condition.

Please note: changes may have been made to the product since the editorial deadline (March 2024). The manufacturer reserves the right to make changes to the design, form, colour and the product specification during the delivery period, provided these changes, while taking into account the interests of the vendor, can be deemed reasonable with respect to the purchaser. Where the vendor or the manufacturer uses symbols or numbers to describe an order or the subject of an order, no rights may be derived solely from these. The illustrations may show accessories and items of optional equipment which are not part of standard specification.

This publication is distributed internationally. However, information regarding statutory regulations, legal requirements and taxation and the consequences thereof applies to the Federal Republic of Germany only and is correct at the time of the editorial deadline. For the definitive latest information, please contact your nearest authorised Mercedes-Benz AG sales partner.

www.mercedes-benz.com.sg

Mercedes-Benz Singapore Pte. Ltd.



CYCLE & CARRIAGE

Mercedes-Benz Singapore Customer Care Center: 1800 329 7540 · cs.sgp@cac.mercedes-benz.com

Cycle & Carriage (Authorised Dealer) – Showroom Enquiries: 6298 1818.

Mercedes-Benz Center, 301 Alexandra Road, Singapore 159968. Mon – Sat: 8.30 am – 7 pm, Sun & PH: 10 am – 6 pm.