



THE NEW GLA.

Mercedes-Benz



## DYNAMIC ALL THE WAY.

Now more than ever, the new GLA combines innovative dynamic elegance with the typical off-road character of an SUV. Its terrain is the city, but the characteristic off-road design elements indicate that trips to the countryside also promise a huge amount of freedom and driving pleasure. Always surrounded by a state-of-the-art interior and classy materials. Off we go!





## CONFIDENT AND DYNAMIC APPEARANCE.

The new Mercedes-Benz GLA stands before you looking compact and powerful, combining sporty elegance with an SUV feel. The view from the side and rear is shaped by the muscular shoulder of the body and the dynamic line of the side windows. And with the longitudinally adjustable second seat row<sup>1</sup>, the space concept offers exceptional practical value.



<sup>1</sup>Optionally selectable equipment depending on configuration.



## EXCITING AND EXPRESSIVE FROM EVERY PERSPECTIVE.

The new GLA impresses with a dynamically optimised design at the front and rear. A striking impression is also left by features such as the optional panoramic sliding sunroof<sup>1</sup>, large light-alloy wheels<sup>1</sup> and the new paint colour spectral blue<sup>1</sup>. And as soon as the doors open, the state-of-the-art interior takes command in terms of expressiveness.



<sup>1</sup>Optionally selectable equipment depending on configuration.





# MBUX.

The second-generation MBUX operating concept is now even more capable of learning and also welcomes you personally. With Touch Control buttons on the steering wheel and by using your voice, touch or gestures you can control the content on the 26 cm (10.25-inch) media display conveniently and intuitively.







## THE FOCUS IS ALWAYS ON THE CONVENIENCE OF OPERATION FOR YOU.

The new multifunction steering wheel with integrated Touch Control panels not only looks good, but also helps keep everything conveniently under control. The new design of the centre console and the practical multimedia connection unit with illuminated USB interfaces are sure to be seen as welcome additions to the high-quality interior.





## Driving assistance systems.

The Active Brake Assist<sup>1</sup> have been optimised with new sensors and cameras, come as standard and relieve the burden on you in everyday life. Further support is also offered by improved systems such as Blind Spot Assist<sup>1, 2</sup> and Parking Assist<sup>1, 2</sup>.

<sup>1</sup>Our driver assistance and safety systems are aids and do not relieve you of your responsibility as a driver. Please take note of the information in the Owner's Manual and the system limits which are described therein.  
<sup>2</sup>Optionally selectable equipment depending on configuration.



## Digital Extras.

With the Digital Extras and the corresponding Mercedes me Apps you experience added convenience, safety, driving enjoyment and digital support, because they provide you with important information and practical functions for your Mercedes, both in the vehicle and on your smartphone.<sup>1</sup>

<sup>1</sup>To use the Mercedes me connect services, you must create a Mercedes me ID and agree to the Terms of Use for the Mercedes me connect services. The services shown, along with their respective availability and functionality, are dependent in particular on the vehicle model, year of build, optional equipment chosen and country.





## MBUX Augmented Reality Navigation (Optional).

With MBUX Augmented Reality Navigation, you stay on the right track at all times, even in complex traffic situations. The system, available as part of our Premium Package, displays high-resolution graphical navigation and traffic information in live images and can help get you to your destination as safely and stress-free as possible.

<sup>1</sup>Optionally selectable equipment depending on configuration.



## New upholstery colours.

An attractive range of interior colours allows individual configuration of your new GLA as required. The Progressive Line, for example, presents itself in the three appointments colours black, macchiato beige and sage grey<sup>1</sup>.

<sup>1</sup>Optionally selectable equipment depending on configuration.





## New centre console.

The retractable cover for the stowage compartment in the centre console offers elegant protection from prying eyes in a high-quality material. This looks good, while the interior appears even neater and everything important is kept to hand. The practical stowage compartment can house typical everyday items such as smartphone, wallet or various keys.

## 48-volt system.

A second on-board electrical system has been established in the new GLA, in the form of the 48-volt system. The 48-volt battery increases the overall battery capacity. This means more electrical energy for innovative functions when stationary, such as climate control. More performance, more flexibility, more efficiency.

## Progressive.

With the Progressive equipment line<sup>1</sup> you can add highlights on and in your Mercedes in a targeted way. The visible tailpipe trims in chrome underscore the dynamic credentials of the SUV on the exterior. In the interior you have a larger selection of colours and materials to choose from for the seat covers.

### HIGHLIGHTS ON THE EXTERIOR

Radiator grille with central Mercedes star and single louvre in grey with trim insert in chrome and accents in high-gloss black

Side sill panels in black with grained finish with trim element in chrome

Polished aluminium roof railing

Simulated underguard at front and rear in chrome

Visible tailpipe trims in chrome

45.7 cm (18-inch) 5-twin-spoke light-alloy wheels aerodynamically optimised, painted in black with a high-sheen finish.

### HIGHLIGHTS IN THE INTERIOR

Comfort suspension seats with optional upholstery in black ARTICO man-made leather

Multifunction sports steering wheel in leather, in 3-spoke design incl. Touch Control panels left and right, as well as black grained steering-wheel gearshift paddles

Star Pattern trim, backlit

Roof liner in black fabric

<sup>1</sup>Optionally selectable equipment depending on configuration.

<sup>1</sup>Optionally selectable equipment depending on configuration.



## Technical data.

	<b>GLA 180 Progressive</b>
No. of cylinders/arrangement	4/In-line
Displacement (cc)	1,332
Rated output (kW[hp]/rpm)	97[130] / 5,500
Rated torque (Nm/rpm)	230 / 1,660 - 3,000
Acceleration 0 - 100 km/h (secs)	9.6
Top speed (km/h)	200
Fuel consumption (l/100km)	6.9
VES band	B

**The best for the engine:**  
Mercedes-Benz genuine engine oils.

The availability of the communication module (LTE) is temporarily limited for certain vehicles due to supply bottlenecks. Please note that especially Mercedes me connect services including the emergency call system (eCall) are not available in the affected vehicles upon delivery. For further enquiry, please contact your Mercedes-Benz Sales Representative or Cycle & Carriage Customer Assistance Centre at 6471 9111. 1 Rated output and torque figures in accordance with Directive 80/1269/EEC in the currently applicable version. 2 Fuel consumption figures are derived from combined tests & tested by local regulations in accordance with UN ECE R101. Under real-life driving conditions deviations may occur in comparison to the certified standard values. The actual values are influenced by a number of individual factors, such as personal driving style, environmental and route conditions. Further technical data may be found on [www.mercedes-benz.com.sg](http://www.mercedes-benz.com.sg).

## Dimensions.

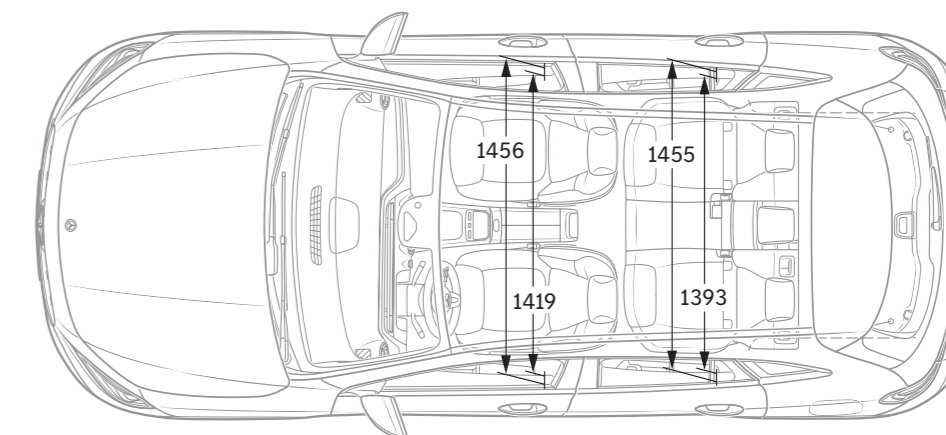
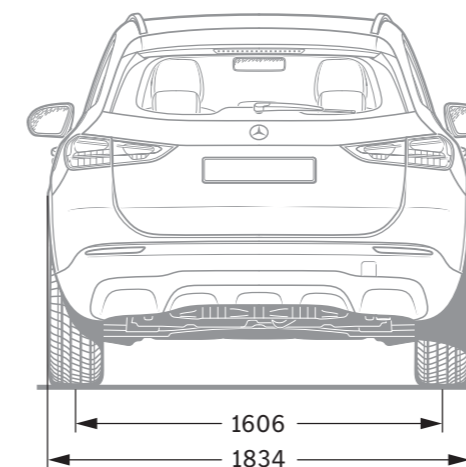
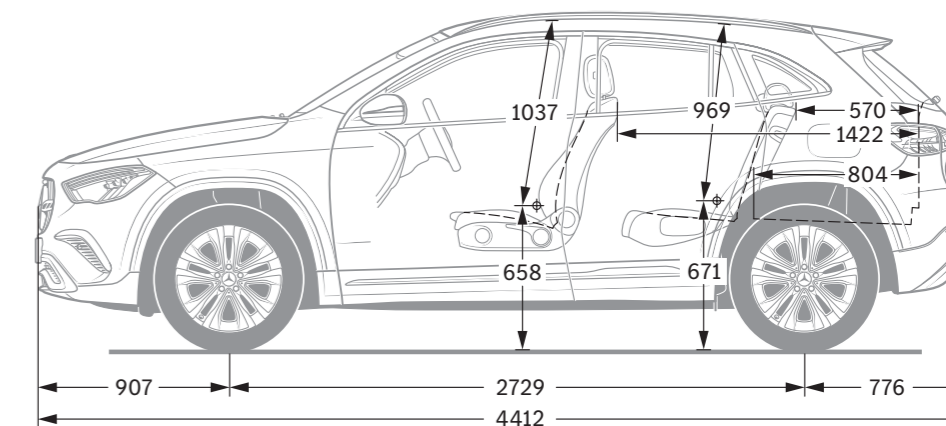
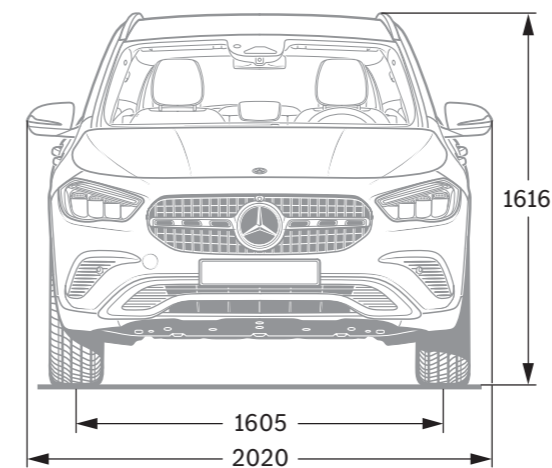

All figures in millimetres. The dimensions shown are mean values. They are valid for vehicles with standard equipment and in unladen condition.



**Please note:** changes may have been made to the product since the editorial deadline (October 2023). The manufacturer reserves the right to make changes to the design, form, colour and the product specification during the delivery period, provided these changes, while taking into account the interests of the vendor, can be deemed reasonable with respect to the purchaser. Where the seller or the manufacturer uses symbols or numbers to describe an order or the subject of an order, no rights may be

derived solely from these. The illustrations may show accessories and items of optional equipment which are not part of standard specification. For current and more specific information in relation to the regulations and requirements in your own country and their consequences, please contact our authorised dealer.

**[www.mercedes-benz.com.sg](http://www.mercedes-benz.com.sg)**

Mercedes-Benz Singapore Pte. Ltd.



**CYCLE & CARRIAGE**

**Mercedes-Benz Singapore Customer Care Center:** 1800 329 7540 · [cs.sgp@cac.mercedes-benz.com](mailto:cs.sgp@cac.mercedes-benz.com)

**Cycle & Carriage (Authorised Dealer) – Showroom Enquiries:** 6298 1818.

Mercedes-Benz Center, 301 Alexandra Road, Singapore 159968. Mon – Sat: 8.30 am – 7 pm, Sun & PH: 10 am – 6 pm.