



EQS SUV  
THIS IS FOR  
PIONEERS.



## This is for pioneers.

Groundbreaking and unique – the EQS SUV. The first all-electric luxury SUV from Mercedes-EQ with space for up to seven people. First-class comfort, innovative features like the MBUX Hyperscreen, and almost silent driving performance. A pioneer on the road – the EQS SUV combines the elegant driving experience of the EQS Saloon with the spaciousness of an SUV.





## Electric mobility in grand style.

A vehicle that sets new standards. The optional multimedia entertainment for the rear-seat passengers and high-quality materials all the way back to the third seat row. Wherever you sit in the EQS SUV, its comfort and stylish appeal mean that you may almost not want to get out again.

## A pioneer on the road.

Spacious and elegant – no longer a contradiction in terms. The new EQS SUV reinvents the SUV idea. An aerodynamically optimised design with an elegantly dynamic silhouette makes for an exceptional appearance as well as ensuring efficient, smooth performance on any road surface.



# Anything but ordinary.

Look the future of mobility in the eye. At the front end, the hallmark radiator grille of the Mercedes-EQ family with Mercedes-Benz pattern, together with the DIGITAL LIGHT headlamps, create an unmistakably futuristic look.





## The new lightness of size and comfort.

The EQS SUV sets new standards in digital driving comfort. In the cockpit, the MBUX Hyperscreen with zero-layer technology spans the entire width of the dashboard. And highlights such as integrated massage seats and an innovative HEPA air filter system ensure outstanding comfort during the journey.



## Welcome to the future of electric mobility.

Elegant and stylish in every detail – the exterior of the EQS SUV boasts an array of exceptional design highlights. Most striking of all are the tail lamps in a 3D helix design, flush-fitting door handles and illuminated running boards.



True greatness comes from within.

Space for life – whether for big families or big shopping sprees, the generous space inside the EQS SUV is variable and versatile. A third seat row is available, creating room for up to seven passengers.





## Long range – short charging time.

The EQS SUV combines high performance with efficiency. You can achieve an electric range of up to 610 km (WLTP), depending on the motor, while also doing your bit for the environment. Because Mercedes me Charge not only gives you access to a global infrastructure of state-of-the-art charging stations, it also includes Green Charging – so you can be sure that any energy you use for charging will be compensated for by feeding an equivalent amount of energy from renewable sources into the grid. This is ensured by the purchase of high-quality certificates of origin.





## MBUX multimedia system.

Experience exciting entertainment with highlights such as the MBUX multimedia system, MBUX Hyperscreen and MBUX Augmented Reality with the optional Head-up Display equipment. All that remains is to decide whether you would prefer to sit in the first or second row of seats.

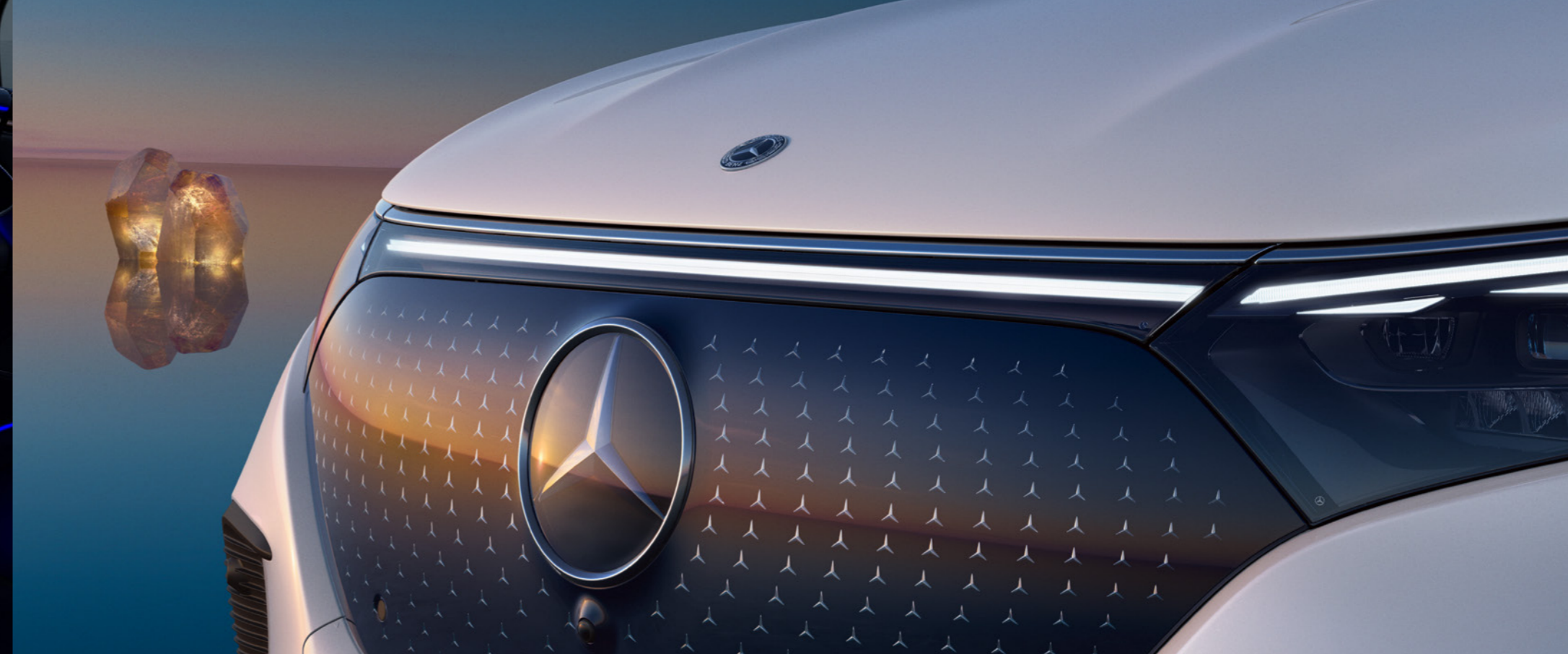

## Assistance systems.

Intelligent features in your EQS SUV help you make the most of the vehicle's capabilities. Driving assistance systems and a range of drive programs encourage an energy-saving and anticipatory driving style. And efficiency-enhancing recuperation means you get the maximum out of your vehicle.

Our driver assistance and safety systems are merely aids, and do not relieve you of your responsibility as the driver. Please take note of the information in the owner's manual and the system limits which are described therein.



## Multicontour seats for driver and front passenger.

Give yourself a treat: these multicontour seats (standard for AMG Line only) combine a wealth of adjustment options with exclusive feel-good extras. Individually inflatable air chambers make it possible to achieve the ideal seating position for you, coupled with intensive lateral support. The soothing massage effects, optionally with comforting warmth, make every journey a pleasure.

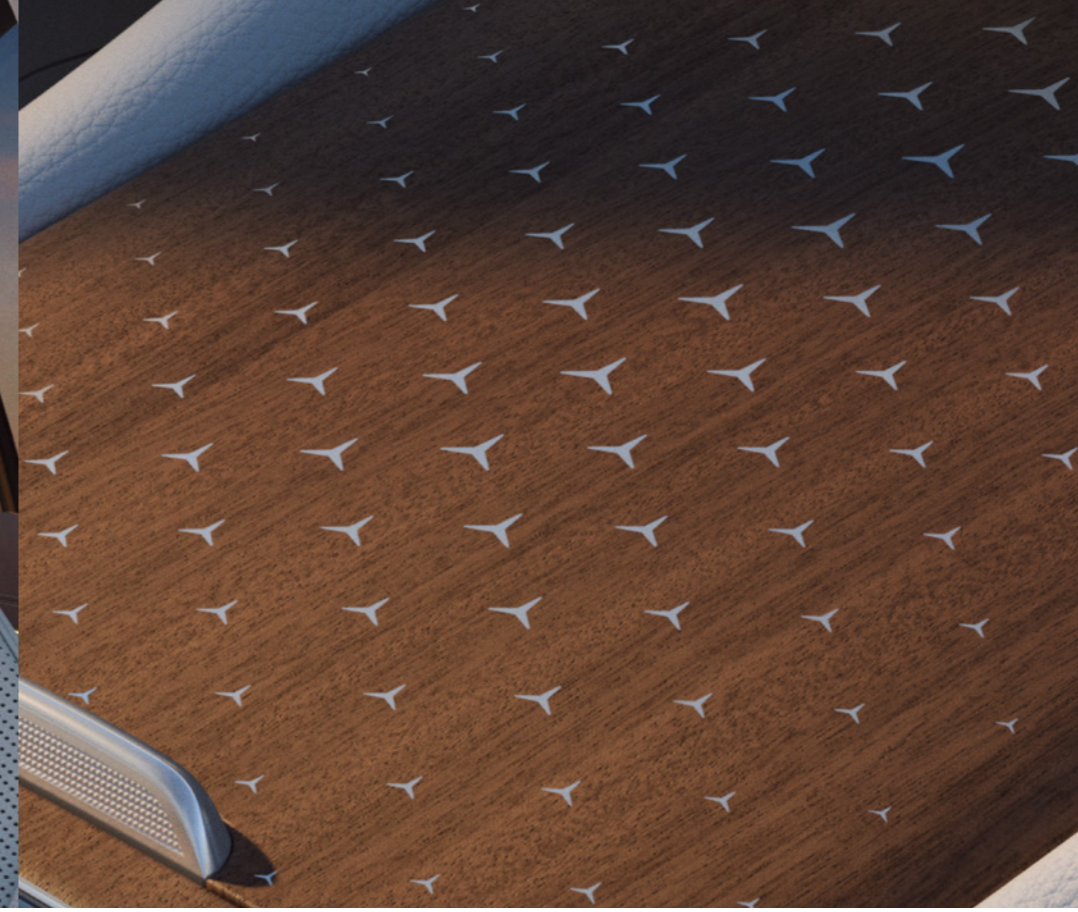

## Exclusive trim elements.

High-quality, timeless, luxurious – the interior is a master class in aesthetics, featuring exclusive trim elements such as open-pore wood with Mercedes-Benz pattern in aluminium.

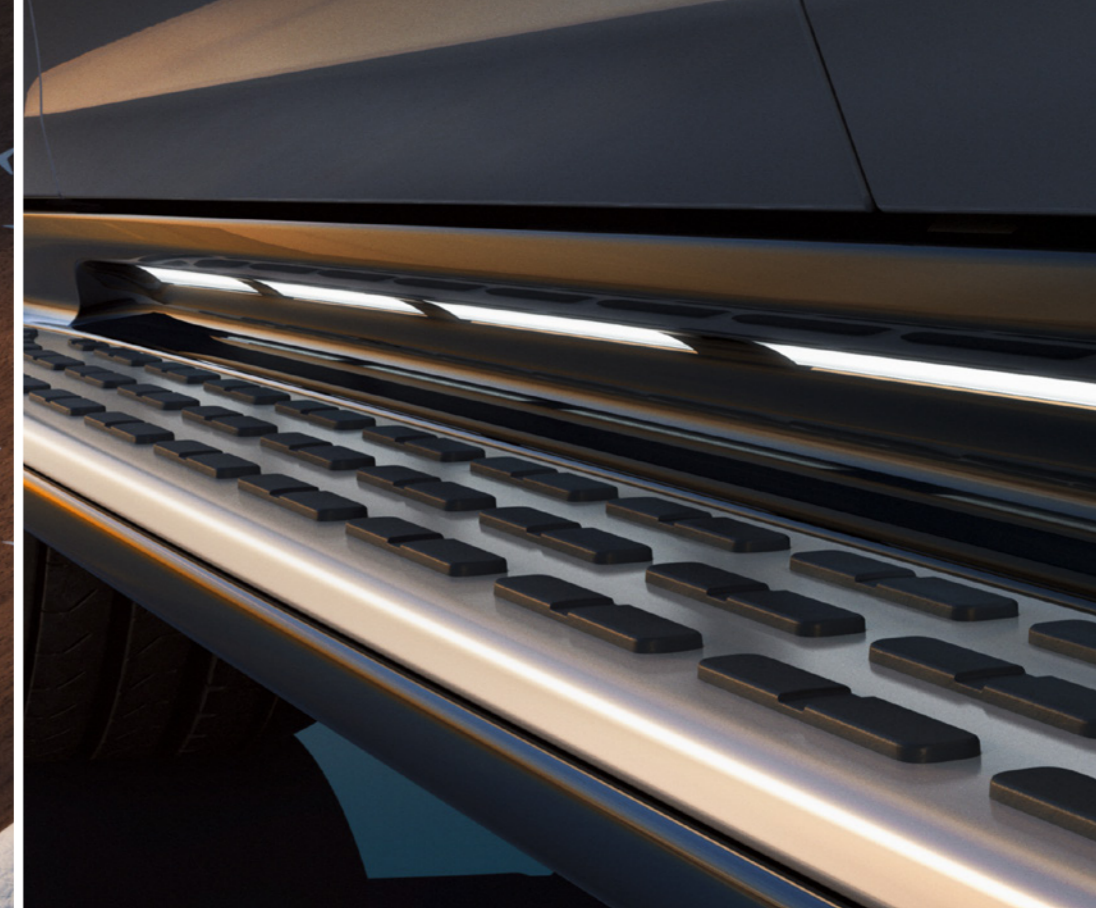

## Illuminated running boards.

The illuminated running boards make it easier to get into your new EQS SUV. As well as making a visual statement, they are aerodynamically optimised.

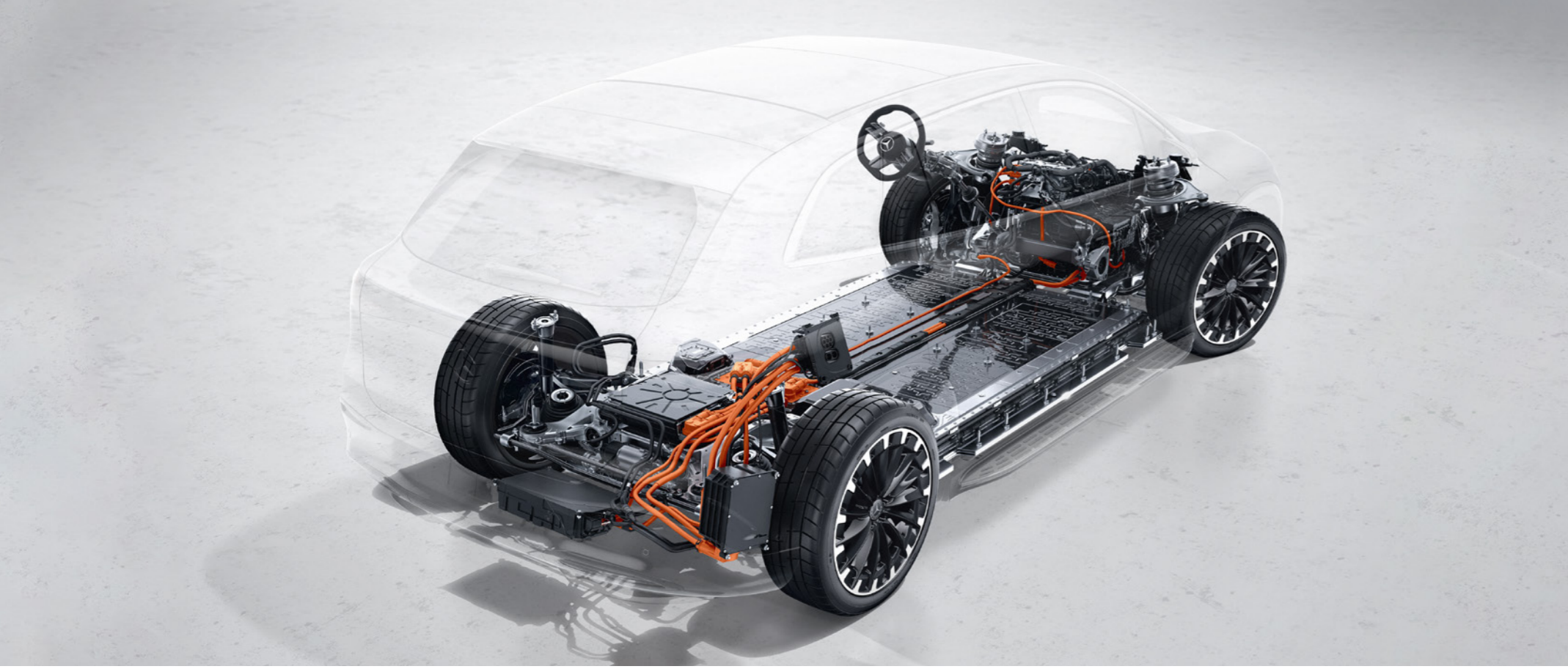

## The new power of electric mobility.

The Electric Vehicle Architecture from Mercedes-EQ provides for a wide range of maximum total outputs from 88kW to 265kW. All EQS SUVs have an electric powertrain (eATS) on the rear axle, while the versions with 4MATIC also have an eATS on the front axle. In the 4MATIC models, the Torque Shift function ensures intelligent, stepless distribution of the drive torque between the rear and front electric motors.



## Rear axle steering.

See why Mercedes-Benz leads the way when it comes to parking, too – the rear axle steering adjusts the steering angle by up to 4.5° and significantly reduces the turning circle. Your car handles almost like a compact car during manoeuvring. At higher speeds, on the other hand, you drive with the effortless superiority afforded by the long wheelbase.

## Electric Art Line.

An ingenious take on superior luxury – the Electric Art exterior accentuates your vehicle's design. Large trim elements in chrome and 21-inch light-alloy wheels emphasise the impressive dimensions. With the Electric Art interior, you can feel progressive luxury in every fibre of the interior. Attractive comfort seats with elegant contour lighting invite you to take your place behind the multifunction steering wheel in nappa leather. In addition, the ambient lighting orchestrates an array of atmospheric colour concepts.



## AMG Line.

Underline the dynamic side of your vehicle with the expressive styling of the AMG Line. Combine the unmistakable purpose design with the sporty genes of Mercedes-AMG. The AMG Line interior lends your Mercedes a more visible and tangible sense of sportiness. In addition to the progressive aesthetics of the interior, the multifunction sports steering wheel with flattened bottom section and perforated grip area enhances driving pleasure. Sports seats with a dynamic seat upholstery layout give you excellent lateral support.



## Technical data.

	EQS 450 4MATIC SUV Electric Art	EQS 450 4MATIC SUV AMG Line
<b>Electric motor</b>		
Rated output (kW [hp])	265 [360]	265 [360]
Electric range (km) (WLTP)	Up to 610	Up to 610
Acceleration from 0 to 100 km/h (s)	6.0	6.0
Top speed (km/h)	210	210
<b>Consumption</b>		
Power consumption (kWh/100km)	20.5	20.5
Equivalent CO2 emissions (g/km)	82	82
VES band	A1	A1
<b>High-voltage battery</b>		
Usable capacity (kWh)	108.4	108.4
Max. charging capacity DC (kW)	200	200
Max. charging capacity AC (kW)	22	22
DC charging time 10–80% SOC (net) (min)	31	31
AC charging time 10–100% SOC (net) Wallbox/public 11 kW WEU (h)	11.25	11.25
AC charging time 10%–100% SOC (net) at household socket 2.3 kW (h)	16.75	16.75

## Dimensions.

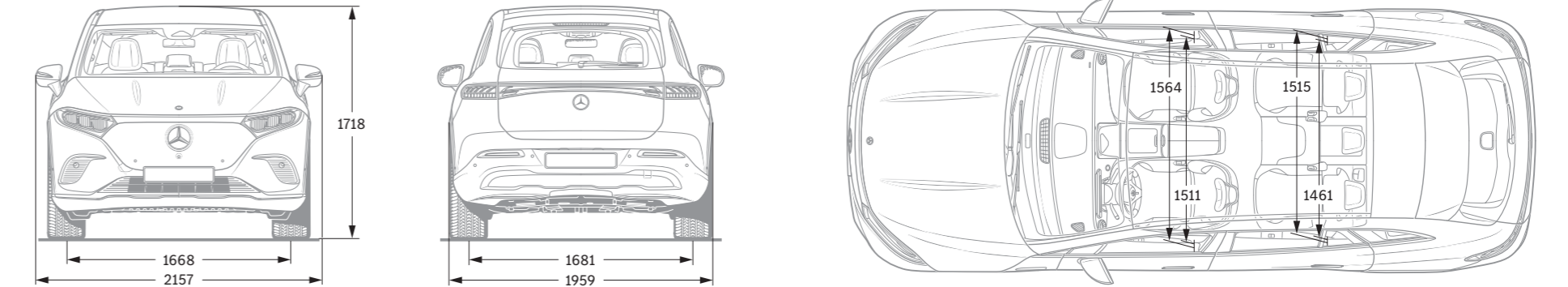

### Standard equipment

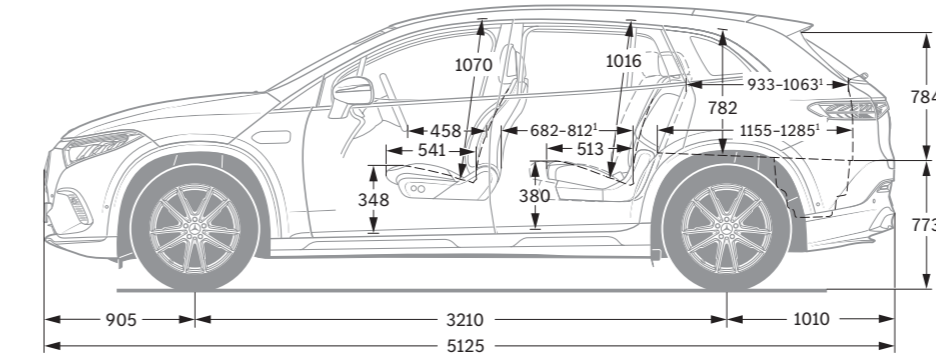

### With 3rd seat row

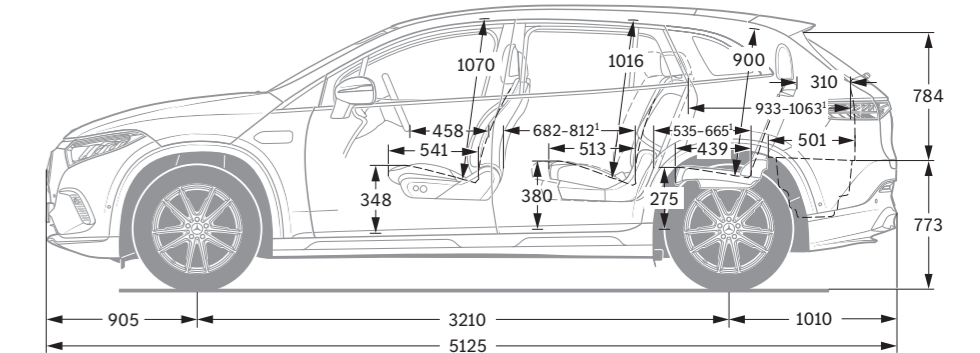

<sup>1</sup> Movable rear bench seat. All figures in millimetres. The illustrated dimensions are mean values. They are valid for vehicles in basic specification and in unladen condition.

**Please note:** changes may have been made to the product since the editorial deadline (August 2023). The manufacturer reserves the right to make changes to the design, form, colour and the product specification during the delivery period, provided these changes, while taking into account the interests of the vendor, can be deemed reasonable with respect to the purchaser. Where the seller or the

manufacturer uses symbols or numbers to describe an order or the subject of an order, no rights may be derived solely from these. The illustrations may show accessories and items of optional equipment which are not part of standard specification. For current and more specific information in relation to the regulations [www.mercedes-benz.com.sg](http://www.mercedes-benz.com.sg)

Mercedes-Benz Singapore Pte. Ltd.



**Mercedes-Benz Singapore Customer Care Center:** 1800 329 7540 · [cs.sgp@cac.mercedes-benz.com](mailto:cs.sgp@cac.mercedes-benz.com)

**Cycle & Carriage (Authorised Dealer)** – Showroom Enquiries: 6298 1818.

Mercedes-Benz Center, 301 Alexandra Road, Singapore 159968. Mon – Sat: 8.30 am – 7 pm, Sun & PH: 10 am – 6 pm.