

# The EQC SUV



MERCEDES-EQ





## Electric now has a Mercedes.

Embark on a new era. With the all-electric EQC. Smooth progress, practically silent operation and zero local emissions. A captivating and carefree driving experience. Thanks to all-new mobility services and driving safety at the highest Mercedes-Benz level.







## The EQC changes the way we look at the automobile.

Pioneering mobility is written all over the face of the new EQC. Elements that used to be separated, such as the headlamps and the radiator grille, are now brought together in a fascinating “black panel” radiator grille. The expressive styling of the AMG Line shown here lends the exterior an exciting, dynamic touch. With a specific front apron, distinct rear diffuser and optional AMG High Performance light-alloy wheels.





## Electric driving at its finest.

The new EQC welcomes you with a new, progressive interior. Many of the trim elements, upholstery materials and colours have been developed exclusively for the EQC and underscore its uniqueness. The instrument display and the media display combine to create a Widescreen Cockpit behind an elegant glass front. A uniquely sophisticated, high-quality look and feel.



## Digital services and intelligent technologies.

The Remote & Navigation Services provide a cluster of services relating to electric driving, including route planning functionalities. Convenient remote control of charging times and pre-entry climate control is also possible.





New services for the  
reassuring feeling  
of driving a Mercedes.

There is a wide range of services available – leaving you to enjoy the  
all-electric driving experience in the new EQC without a care in the world.







## Even more alluring in the EQ: The Mercedes-Benz User Experience.

MBUX offers users maximum freedom to control all functions in the way that is most comfortable and convenient to them, by using natural speech or intuitive touch control, for example. The media display in the new EQ is designed as a touchscreen, while the centre console includes an integral touchpad that responds to single and multiple-finger gestures as well as handwriting.



## Electric driving according to Mercedes-Benz safety standards.

Latest-generation driver assistance systems can warn the driver in a manner appropriate to the situation, provide support and even react automatically, for example to maintain the distance to the car in front, hold the vehicle's speed or remain in lane. All these are available with the optional Driving Assistance package.







## MULTIBEAM LED.

The new EQ takes in its surroundings literally at the speed of light, largely thanks to the standard MULTIBEAM LED headlamps with inner housing in high-gloss black, blue trim lines and a distinctive light design. The LED light bands at the front and rear really catch the eye and draw attention, particularly at night.



## Burmester® surround sound system.

Experience more performance and exclusivity with the optional unique sound systems from Burmester®. The high-performance speakers deliver first-class surround sound. You can specifically optimise this for the front and rear seats to intensify the listening experience.



## EQC-specific light-alloy wheels.

We've rethought almost everything for the EQC. Even the wheels, which are available in a design developed specifically for the EQC, with optional blue detailing.



## ENERGIZING Package Plus.

The optional ENERGIZING Package Plus combines luxurious optional extras to create comfort programs that enhance your physiological safety and sense of well-being. The result is quite fascinating: your Mercedes can vitalise and cosset you in specific ways. All these, for prolonged alertness at the wheel and an exceptionally pleasant drive. The ten-minute programs direct the climate control, ambient lighting, music and seat functions such as massage, heating or ventilation.



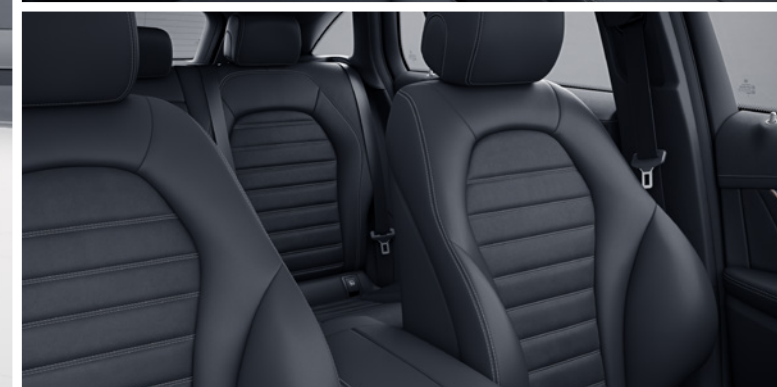
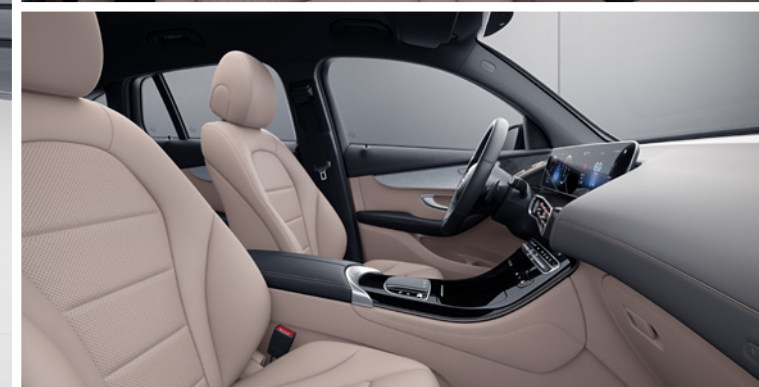

## Electric Art.

A truly special vehicle at first glance – with a design that represents the future. The black panel radiator grille and the specific MULTIBEAM LED headlamps are unmistakable, and combined here to spectacular effect with an LED luminescent band. The interior blends special electric-car aesthetics with the impressive interplay between a contemporary colour scheme and the hallmark intrinsic value of a Mercedes-Benz.

### ELECTRIC ART EXTERIOR HIGHLIGHTS

Black panel radiator grille with louvres and surround in chrome

MULTIBEAM LED and LED light bands at the front and rear

Front apron and side sill panels in black

Aerodynamically optimised 19-inch alloy wheels

Badge on the wing in high-gloss black with chrome stripes and blue “EQ” lettering

### ELECTRIC ART INTERIOR HIGHLIGHTS

Seats upholstered in ARTICO man-made leather

Multifunction sports steering wheel in leather with chrome spokes and control panels in high-gloss black with chrome control

Instrument panel with nappa-look man-made leather.

Beltlines with a fine surface structure in black

Ventilation outlets with rosé gold-coloured louvres

Fabric roof liner, black

## The AMG Line.

The expressive styling of the AMG Line lends the exterior an exciting, dynamic touch, bringing sporty AMG genes into the realm of electric mobility – your clear statement in support of combining unique design with equally unique technology. The AMG Line interior lends the interior a more visible and tangible sense of sportiness alongside the electric-car aesthetics.

### AMG LINE EXTERIOR HIGHLIGHTS

AMG-specific black panel radiator grille in twin-blade design and with surround in high-gloss black

AMG-specific front apron in jet-wing design, air intakes with chrome trim elements and high-gloss black trim inserts as well as visible and functional AIR CURTAINS

Wider, AMG-specific rear apron with visible air outlets (not functional), diffuser insert with four aero ribs in black and chrome trim element

Aerodynamically optimised 19-inch AMG alloy wheels

### AMG LINE INTERIOR HIGHLIGHTS

Sports seats with AMG-specific leather upholstery

Multifunction sports steering wheel in nappa leather with flattened bottom section, perforated in the grip area

Instrument panel with nappa-look man-made leather in metallic silver grey and edging in rosé gold. Beltlines with a fine surface structure in black, topstitching in rosé gold or mid grey

AMG sports pedals in brushed stainless steel with black rubber studs and AMG floor mats



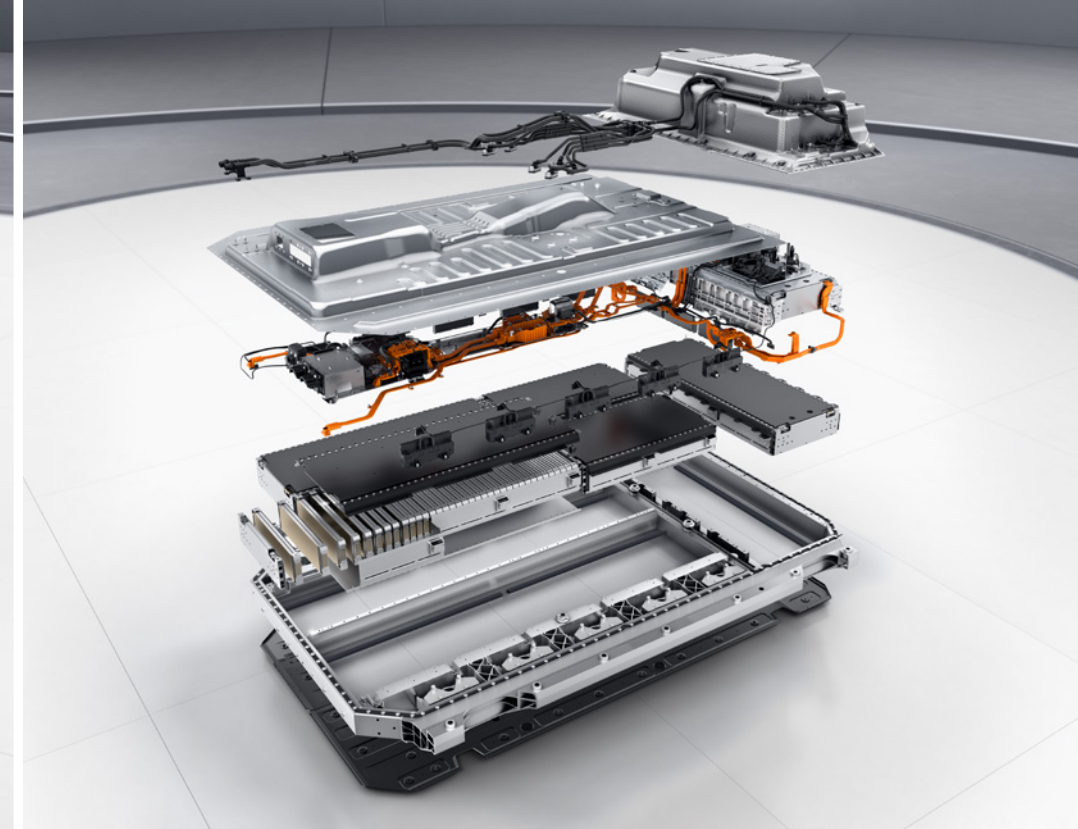
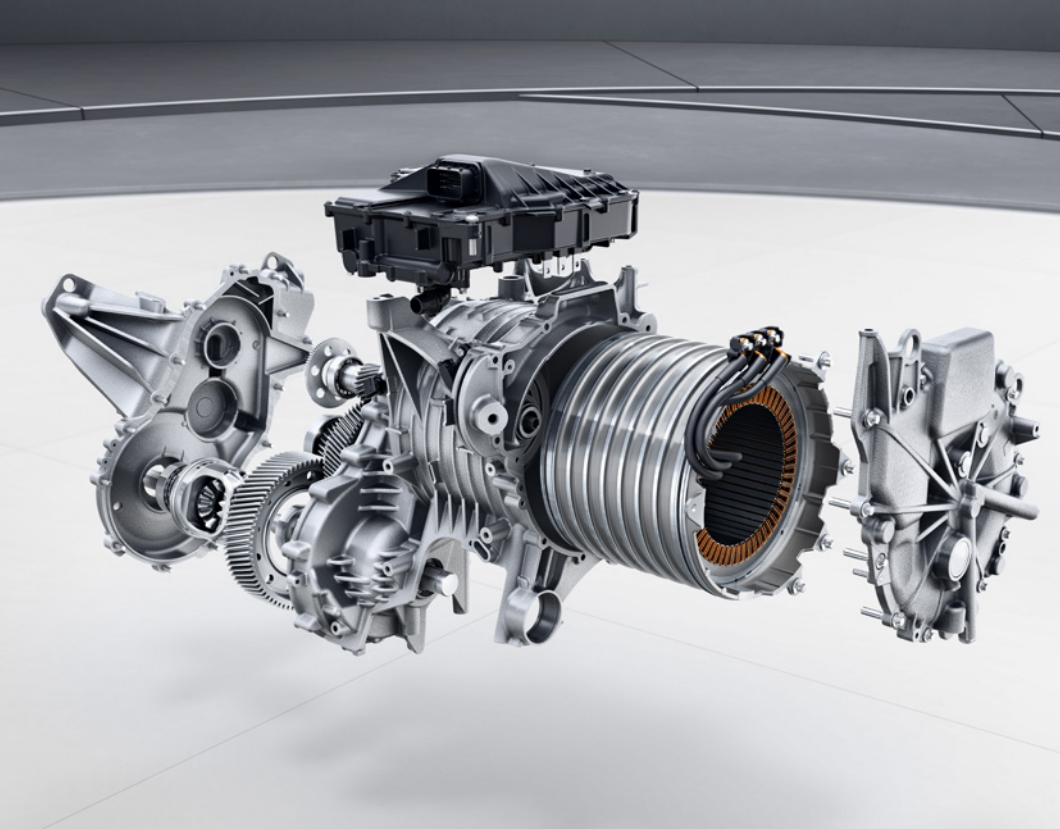

## Electric drivetrain.

An electric motor on each of the axles converts electrical energy into mechanical energy for impressive forward thrust. Thanks to the intelligent operating strategy of the drive components, the system output of 300 kW ensures efficient and practically silent operation. The electric drivetrains have different configurations in order to minimise electrical consumption and maximise dynamism: the electric motor at the front is optimised to provide maximum efficiency in low to medium load ranges, while its rear counterpart determines the dynamism.

## Driving Assistance Package.

Join the road to fully automated driving: cutting-edge systems support you according to the given situation with speed adjustment, steering, lane changes and even when there is a risk of collision. The risk of an accident is reduced – passengers as well as other road users are protected effectively. So you reach your destination relaxed and safe.

The optional Driving Assistance package includes a wealth of sensors for your Mercedes: cameras, radar and ultrasound scan the surroundings. All information is intelligently networked. What you as a driver gain in terms of comfort is permanently noticeable in the way you are relieved of much of the strain. For example, the systems can take care of braking and accelerating for you, while smooth steering intervention helps you to keep the vehicle in lane.



## Technical data.

	EQC 400 4MATIC Electric Art	EQC 400 4MATIC AMG Line
Engine capacity <sup>1</sup> (electric) (kW)	310	310
Peak power output <sup>1</sup> (electric) (kW)	300	300
Rated torque (Nm / rpm)	760 / 0 - 2,000	760 / 0 - 2,000
Acceleration 0 - 100 km/h (secs)	5.1	5.1
Top speed (km/h)	180	180
Battery capacity (kWh)	80	80
Energy consumption <sup>2</sup> (kWh/100km)	21.5	21.5
VES band	A1	A1

## Dimensions.

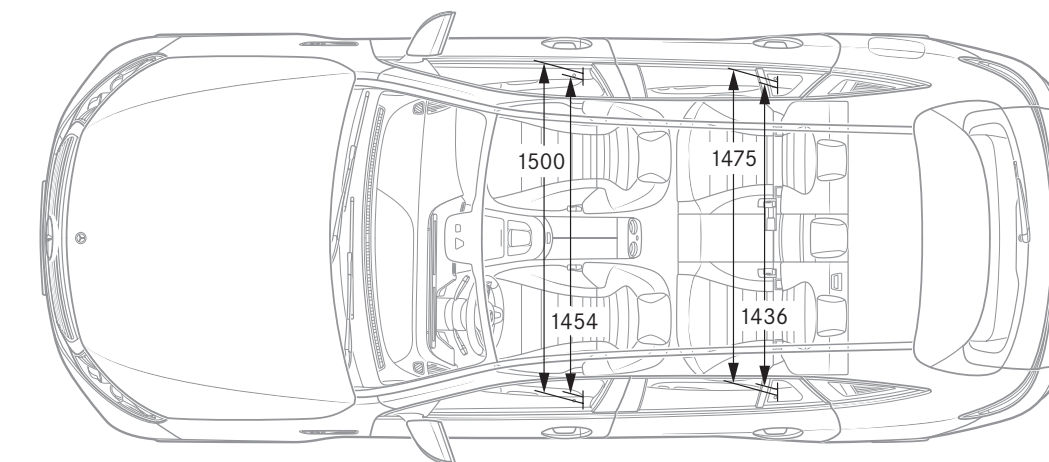
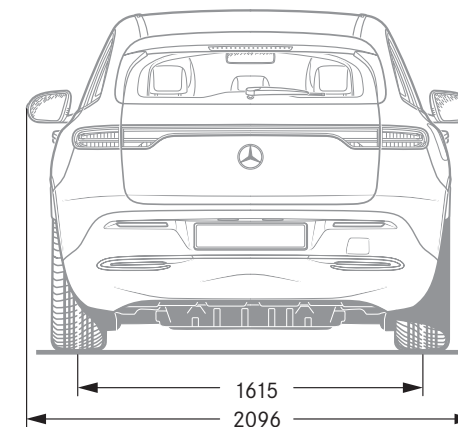
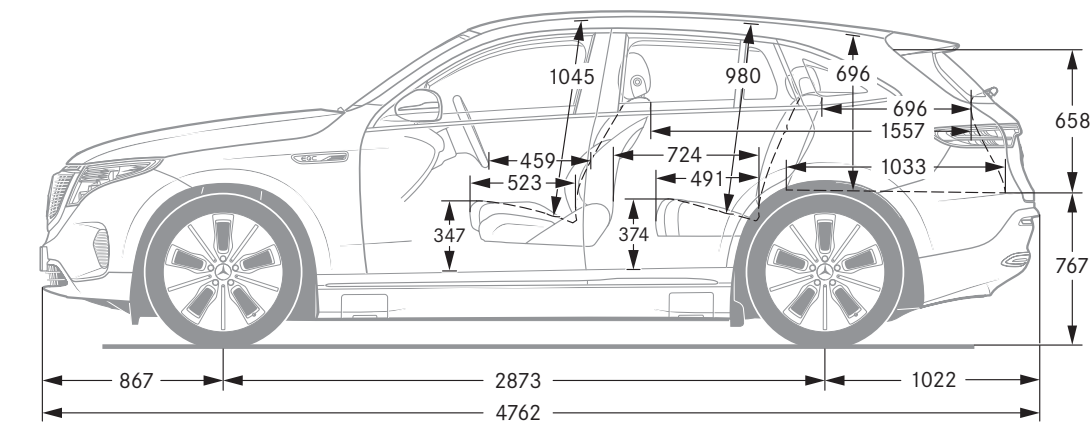
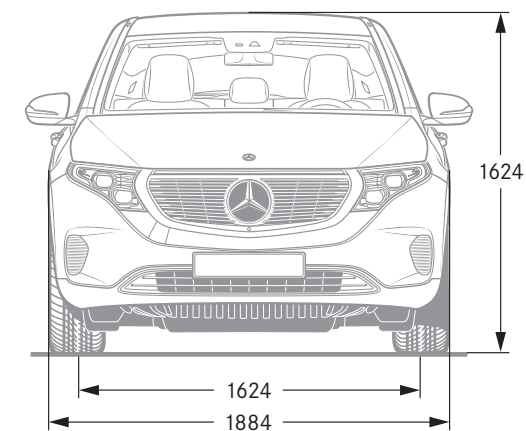

The availability of the communication module (LTE) is temporarily limited for certain vehicles due to supply bottlenecks. Please note that especially Mercedes me connect services including the emergency call system (eCall) are not available in the affected vehicles upon delivery. For further enquiry, please contact your Mercedes-Benz Sales Representative or Cycle & Carriage Customer Assistance Centre at 6471 9111.

<sup>1</sup>Engine capacity, peak power output, and torque figures in accordance with Directive 80/1269/EEC in the currently applicable version. <sup>2</sup>Energy consumption figures are derived from combined tests & tested by local regulations in accordance with UN ECE R101. Under real-life driving conditions deviations may occur in comparison to the certified standard values. The actual values are influenced by a number of individual factors, such as personal driving style, environmental and route conditions. Further technical data may be found on [www.mercedes-benz.com.sg](http://www.mercedes-benz.com.sg).

All figures in millimetres. The pictured dimensions are mean values. They are valid for vehicles with standard equipment and in unladen condition.



# Upholstery.

## Upholstery

- 111 ARTICO man-made leather – black
- 115 ARTICO man-made leather – silk beige / black
- 251 Leather – black
- 651 ARTICO man-made leather / DINAMICA microfibre – black

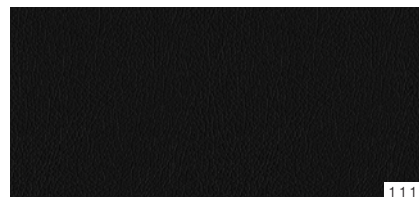

111



115

### AMG Line

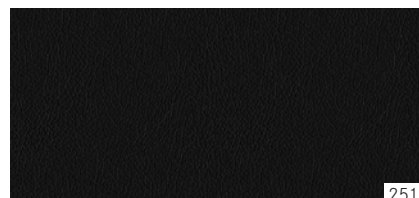

251

### AMG Line

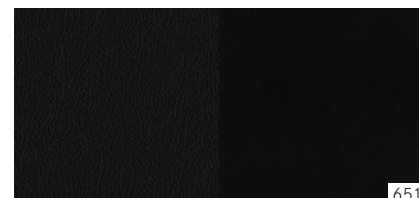

651

# Trim.

## Trim

- 736 Open-pore black ash wood trim
- H63 Grey matrix-look trim
- H65 Anthracite carbon-fibre-look trim
- H66 Aluminium-look trim

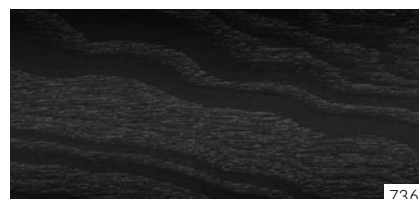

736

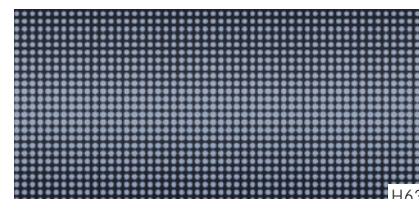

H63

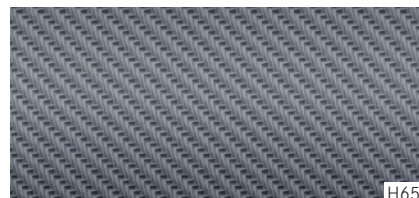

H65

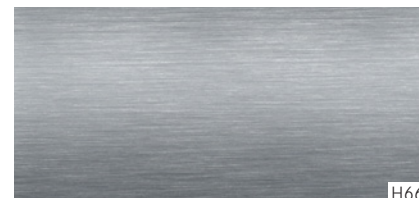

H66

# Paintwork.

## Paintwork

### Non-metallic paints

- 040 Black
- 149 Polar White

### Metallic paints

- 197 Obsidian Black
- 831 Graphite Grey
- 859 Mojave Silver
- 890 Cavansite Blue
- 896 Brilliant Blue
- 922 High-Tech Silver
- 992 Selenite Grey

### designo paints\*

- 297 Designo Selenite Grey Magno
- 799 Designo Diamond White Bright
- 996 Designo Hyacinth Red Metallic

\*Optional Extra

### Non-metallic paints

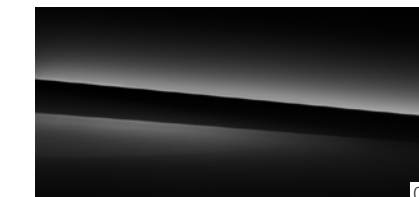

040



149

### Metallic paints

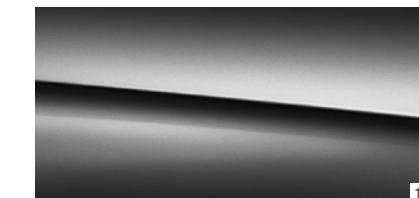

197

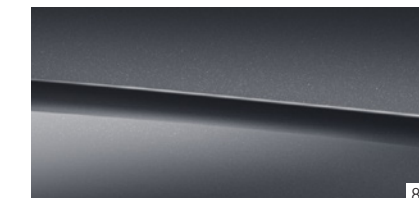

831

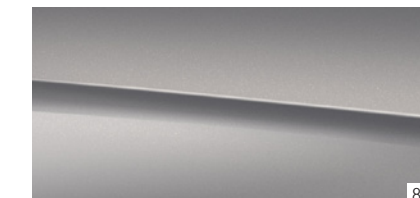

859

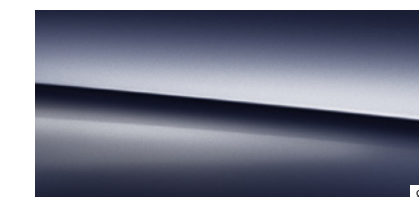

890

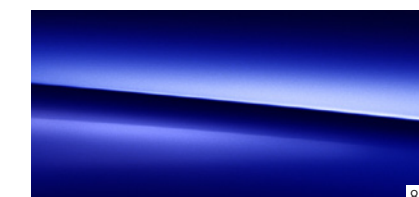

896



922

### designo paints

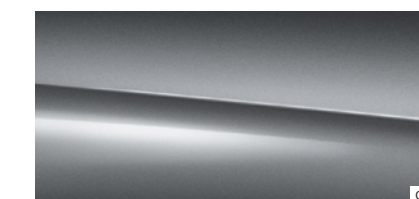

297

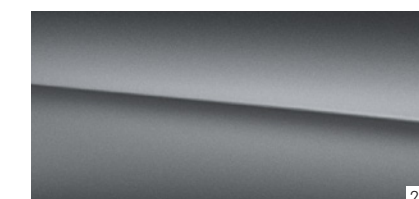

799



996



996





# SPORT - F O R - GOOD

Mercedes-Benz AG is one of the founding partners of the worldwide "Laureus Sport for Good Foundation", which was established in 2000. It is the Mercedes-Benz brand's most important social initiative. Laureus Sport for Good supports children and young people in need through social sports projects, opening up new perspectives and imparting important values such as team spirit, respect and determination. "Change the Game for Kids" is our mission statement which we wish to share with you. In buying a Mercedes-Benz you are supporting the "Laureus Sport for Good" movement.

**Please note:** changes may have been made to the product since the editorial deadline (June 2021). The manufacturer reserves the right to make changes to the design, form, colour and the product specification during the delivery period, provided these changes, while taking into account the interests of the vendor, can be deemed reasonable with respect to the purchaser. Where the seller or the manufacturer uses symbols or numbers to describe an order or the subject of an order, no rights may be

derived solely from these. The illustrations may show accessories and items of optional equipment which are not part of standard specification. For current and more specific information in relation to the regulations and requirements in your own country and their consequences, please contact our authorised dealer. [www.mercedes-benz.com.sg](http://www.mercedes-benz.com.sg)

Mercedes-Benz Singapore Pte. Ltd.



**Mercedes-Benz Singapore Customer Care Center:** 1800 329 7540 · [cs.sgp@cac.mercedes-benz.com](mailto:cs.sgp@cac.mercedes-benz.com)  
**Cycle & Carriage (Authorised Dealer)** - Showroom Enquiries: 6298 1818.  
Mercedes-Benz Center, 301 Alexandra Road, Singapore 159968. Mon - Sat: 8.30 am - 7 pm, Sun & PH: 10 am - 6 pm.