

The CLS Coupé



Mercedes-Benz



The new CLS.

With its symbiosis of coupé and saloon, the CLS established a new category. In its new edition, the four-door coupé remains true to its clean lines and typical silhouette, complemented by expressive design details and sporty accents. Once more the CLS presents itself as a progressive style icon.



Style icon from front to rear end.

Clear lines determine the effortlessly superior appearance of the new CLS. With a reduction to the essentials, the sensual design idiom and iconic form complement each other to create a contemporary, luxury feel. The new front with the star grille, multi-spoke wheels in an aero design and sharply drawn headlamps add powerful highlights.





Expressiveness to the core.

It is the many details that make the interior of the new CLS so breathtaking. Fine materials, paired with innovative ease of operation, add up to a superior-class interior. And for individualists the multifunction steering wheel, trim element and the sporty seats can be personalised totally according to their wishes.

Safe companion from parking space to overtaking lane.

Thanks to state-of-the-art safety and assistance systems the new CLS can support you in a way appropriate to the situation in question and can actively help to reduce risks in road traffic. The optional Driving Assistance Plus package with Active Stop-and-Go Assist and Active Distance Assist DISTRONIC takes the strain off you, ensuring that you reach your destination safely, above all, but also relaxed.



The image shows the front interior of a Mercedes-Benz CLS. The seats are upholstered in a rich brown leather with a vertical ribbed pattern and perforated sections for ventilation. The headrests are also in the same leather. The door panel on the left features a silver door handle and a control panel with buttons labeled '1', '2', '3', and 'M'. The exterior of the car, visible through the window, is a vibrant yellow. The overall lighting is soft and focused on the seats, creating a sense of luxury and comfort.

Wellness coach for all the senses.

Comfort is a holistic experience in the new CLS. The optional ENERGIZING Package, for example, actively improves the well-being of the driver and front passenger – even during the journey. The digital cockpit networks the virtual world with the real world, while the Burmester® surround sound system supplies the perfect soundtrack.



Sets trends that become timeless.

Clear design lines and absolute proportions make it unmistakably clear: the CLS is an icon. But in its new edition the four-door coupé goes even further and, thanks to the individualisation range, is more versatile than ever before. The new CLS thus not only has strength of character, but also a personality: yours.



Highlight of a new stellar era.

The many design elements of the AMG Line make the new CLS even more expressive in its appeal. In particular the restyled front with the star grille makes the coupé an absolute eyecatcher and pays homage to the legendary Mercedes star. Further sporty highlights of the AMG Line underscore the progressive spirit of the new CLS.

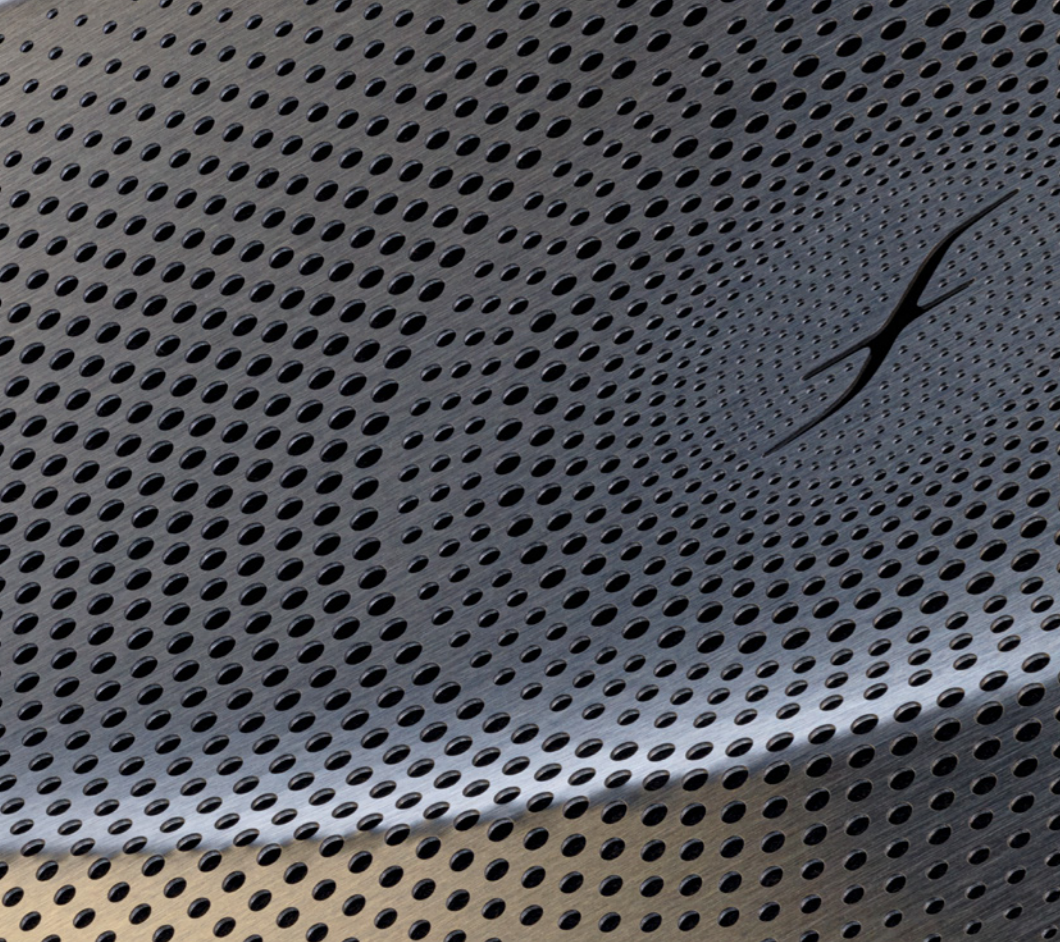

Burmester® sound system.

The high-quality speakers of the Burmester® surround sound system develop an impressive soundscape on board the new CLS. As fine as their sound, the design of the speakers also features characteristically styled metal covers that integrate perfectly into the exciting interior concept.

Ambient lighting.

The ambient lighting allows you to adjust the lighting mood in the CLS to suit your preferences at the touch of a button. 64 colours, selected colour schemes and lighting effects immerse the ventilation outlets, doors and instrument panel in an exciting play of colours, which also adapts dynamically to the driving experience via the optional ENERGIZING comfort control.

Comfort driving assistance.

With the optional Driving Assistance Plus Package, the safety offering of the new CLS is extended to include further intelligent systems, such as Active Distance Assist DISTRONIC. This automatically controls the speed in relation to vehicles ahead that are driving more slowly, and in hazardous situations can use Active Brake Assist to intervene.

The AMG Line.

With the distinctive styling of the AMG Line you are opting for a thoroughly sporty design with striking dynamics. Particularly worthy of note: the AMG-specific front apron. The interplay between the features adds a new level of expression all round, which is emphasised further by the lowered suspension.



The Night Package (optional).

With the Night Package your sporty exterior looks even more expressive. Numerous elements are retained in black or high-gloss black. Depending on the paintwork, this creates contrasts or flowing transitions. Whichever you choose: there are always clear benefits in terms of individuality.



The ENERGIZING Package (optional).

Comfort for all the senses: this package combines a series of special equipment features with innovative intelligence. Your Mercedes is able to vitalise you in targeted ways – for prolonged alertness at the wheel and a pleasant drive. With up to five comfort programs, plus extras such as seat heating for driver and front passenger.





DYNAMIC SELECT.

The DYNAMIC SELECT drive programs change the handling characteristics of your Mercedes at the press of a button. They control, for example, the characteristics of the engine, transmission and steering to suit the driving situation. Whether dynamic in Sport mode, really relaxed in Comfort mode or especially economical in Eco mode: you determine the driving style of your journey.

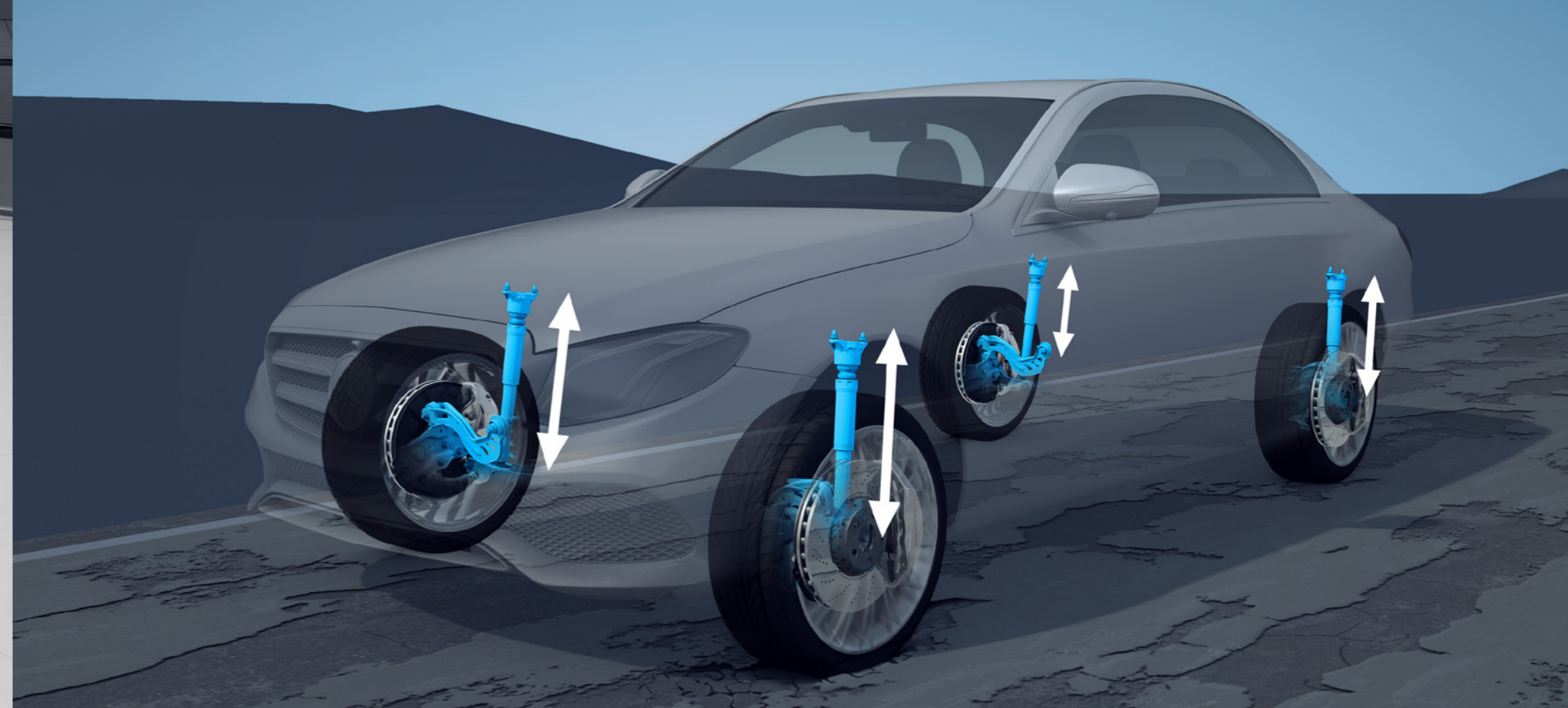

AIR BODY CONTROL.

The optional AIR BODY CONTROL combines the advantages of several suspension systems – you can switch at any time from comfortable to dynamic. The setup range is particularly impressive. That's because the multi-chamber air springs feature three-way control. They can provide excellent ride comfort on difficult terrain or, as an alternative, sporty characteristics. Practical: the self-leveling suspension.

The new CLS.

The Mercedes-AMG CLS 53 4MATIC+.

Every Mercedes-AMG is a masterpiece in its own right, with an unmistakable character. What unites our performance vehicles and sports cars is their irrepressible sporting spirit. Their passion for top performance. It is generated at the point where engineering skill meets a very special attitude: the spirit of AMG. We believe that you have to keep on challenging limits in order to achieve new goals. We accept nothing as a given. Because limits are imposed by people, and it's also people who can overcome them. It's this attitude that enables us to achieve outstanding performance for motor racing – and for the road.

Welcome to the world of AMG.

www.mercedes-amg.com

AMG



Technical data.

	Mercedes-AMG CLS 450 4MATIC Coupé	Mercedes-AMG CLS 53 4MATIC+ Coupé
No. of cylinders/arrangement	In-line 6	In-line 6
Displacement (cc)	2,999	2,999
Rated output ¹ (hp / rpm)	367 / 5,500 - 6,100	435 / 5,500 - 6,100
Rated torque (Nm / rpm)	500 / 1,600 - 4,500	520 / 1800 - 5800
Acceleration 0-100km/h (secs)	4.8	4.5
Top speed (km/h)	250	250
Fuel consumption ² (l/100km)	9.6	9.8
VES band	C2	C2

**The best for the engine:
Mercedes-Benz genuine engine oils.**

The availability of the communication module (LTE) is temporarily limited for certain vehicles due to supply bottlenecks. Please note that especially Mercedes me connect services including the emergency call system (eCall) are not available in the affected vehicles upon delivery. For further enquiry, please contact your Mercedes-Benz Sales Representative or Cycle & Carriage Customer Assistance Centre at 6471 9111.

¹Rated output and torque figures in accordance with Directive 80/1269/EEC in the currently applicable version. ²Fuel consumption figures are derived from combined tests & tested by local regulations in accordance with UN ECE R101. Under real-life driving conditions deviations may occur in comparison to the certified standard values. The actual values are influenced by a number of individual factors, such as personal driving style, environmental and route conditions. Further technical data may be found on www.mercedes-benz.com.sg.

Dimensions.

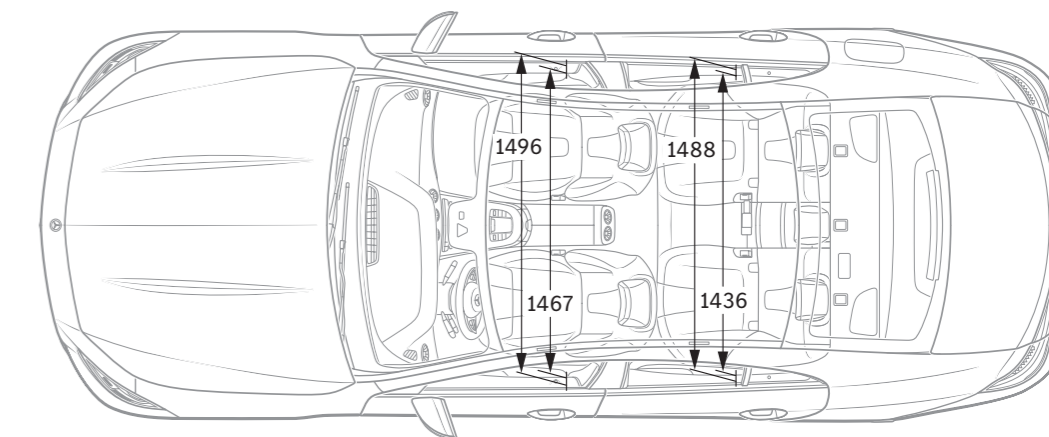
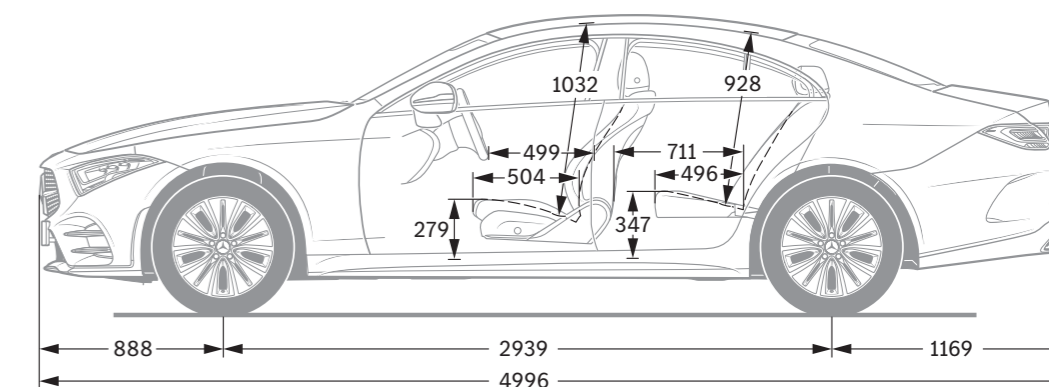
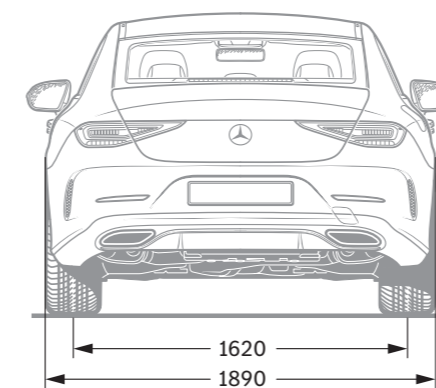
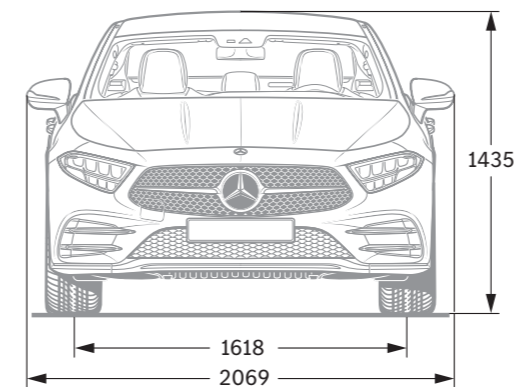

All figures in millimetres. The pictured dimensions are mean values. They are valid for vehicles with standard equipment and in unladen condition.



SPORT - F O R - GOOD

For 20 years now it has been our belief that sport has the power to connect people and motivate them in a unique way. We have facilitated urgently needed access to our support programmes for millions of children and young people, so helping them to achieve positive change in their lives. The programmes that we support together with Laureus Sport for Good are in line with the United Nations' Sustainable Development Goals and are part of an exciting major global movement to effect positive change in the world. **In buying a Mercedes-Benz you are supporting the "Laureus Sport for Good" movement.**

Please note: changes may have been made to the product since the editorial deadline (May 2022). The manufacturer reserves the right to make changes to the design, form, colour and the product specification during the delivery period, provided these changes, while taking into account the interests of the vendor, can be deemed reasonable with respect to the purchaser. Where the seller or the manufacturer uses symbols or numbers to describe an order or the subject of an order, no rights may be

derived solely from these. The illustrations may show accessories and items of optional equipment which are not part of standard specification. For current and more specific information in relation to the regulations and requirements in your own country and their consequences, please contact our authorised dealer. www.mercedes-benz.com.sg

Mercedes-Benz Singapore Pte. Ltd.



Mercedes-Benz Singapore Customer Care Center: 1800 329 7540 · cs.sgp@cac.mercedes-benz.com

Cycle & Carriage (Authorised Dealer) – Showroom Enquiries: 6298 1818.

Mercedes-Benz Center, 301 Alexandra Road, Singapore 159968. Mon – Sat: 8.30 am – 7 pm, Sun & PH: 10 am – 6 pm.